



International Certification Corp.

No. 3-1, Lane 6, Wen San 3rd St., Kwei Shan Hsiang, Tao Yuan Hsien 333, Taiwan, R.O.C.

Tel: 886-3-271-8666

Fax: 886-3-318-0155

# IC Test Report

**IC** : 3147A-WB45NBT  
**Equipment** : 45 Series WB module with Bluetooth  
**Model No.** : WB45NBT  
**Brand Name** : Laird Technologies  
**Applicant** : Laird Technologies  
**Address** : 11160 Thompson Ave. / Lenexa, Kansas /  
66219 / USA  
**Standard** : RSS-210 Issue 8 December 2010  
**Received Date** : May 03, 2013  
**Tested Date** : May 17 ~ Jun. 03, 2013

We, International Certification Corp., would like to declare that the tested sample has been evaluated and in compliance with the requirement of the above standards. The test results contained in this report refer exclusively to the product. It may be duplicated completely for legal use with the approval of the applicant. It shall not be reproduced except in full without the written approval of our laboratory.

Approved & Reviewed by:

Gary Chang / Manager



Testing Laboratory  
2732



## Table of Contents

<b>1</b>	<b>GENERAL DESCRIPTION .....</b>	<b>5</b>
1.1	Information.....	5
1.2	Test Setup Chart.....	7
1.3	The Equipment List .....	8
1.4	Test Standards .....	11
1.5	Measurement Uncertainty .....	11
<b>2</b>	<b>TEST CONFIGURATION.....</b>	<b>12</b>
2.1	Testing Condition .....	12
2.2	The Worst Test Modes and Channel Details.....	12
<b>3</b>	<b>TRANSMITTER TEST RESULTS .....</b>	<b>13</b>
3.1	Conducted Emissions .....	13
3.2	6dB and Occupied Bandwidth .....	16
3.3	RF Output Power .....	19
3.4	Power Spectral Density .....	21
3.5	Unwanted Emissions into Restricted Frequency Bands .....	23
3.6	Unwanted Emissions into Non-Restricted Frequency Bands.....	67



## Release Record

Report No.	Version	Description	Issued Date
CR350301AI	Rev. 01	Initial issue	Aug. 20, 2013



## Summary of Test Results

IC Rules	Test Items	Measured	Result
7.2.4 of RSS-Gen	Conducted Emissions	[dBuV]: 0.153MHz 50.72 (Margin -15.10dB) - QP	Pass
A8.5 of RSS-210	Radiated Emissions	[dBuV/m at 3m]: 61.24MHz 38.76 (Margin -1.24dB) - QP	Pass
A8.4 of RSS-210	Fundamental Emission Output Power	Power [dBm]: 11a: 24.23 HT20: 24.13	Pass
A8.2 of RSS-210	6dB Bandwidth	Meet the requirement of limit	Pass
A8.2 of RSS-210	Power Spectral Density	Meet the requirement of limit	Pass
N/A	Antenna Requirement	Meet the requirement of limit	Pass



# 1 General Description

## 1.1 Information

### 1.1.1 Specification of the Equipment under Test (EUT)

RF General Information					
Frequency Range (MHz)	IEEE Std. 802.11	Ch. Freq. (MHz)	Channel Number	Transmit Chains (N <sub>TX</sub> )	Data Rate / MCS
5725-5850	a	5745-5825	149-165 [5]	1	6-54 Mbps
5725-5850	n (HT20)	5745-5825	149-165 [5]	1	MCS 0-7

Note 1: RF output power specifies that Maximum Conducted Output Power.  
Note 2: 802.11a/n uses a combination of OFDM-BPSK, QPSK, 16QAM, 64QAM modulation.

### 1.1.2 Antenna Details

Ant. No.	Model	Type	Connector	Operating Frequencies (MHz) / Antenna Gain (dBi)				
				2400~2483.5	5150~5250	5250~5350	5470~5725	5725~5850
1	MAG.LAYERS EDA-1513-25GR 2-B2-CY	Dipole	SMA Jack Reverse	2	2	2	2	2
2	MAG.LAYERS PCA-4606-2G4C 1-A13-CY	PCB Dipole	UFL	2.21	2.21	2.21	2.21	2.21
3	Laird NanoBlade-IP04	PCB Dipole	UFL	2	3.9	3.9	4	4
4	Laird MAF95310 Mini NanoBlade Flex	PCB Dipole	UFL	2.79	3.38	3.38	3.38	3.38
5	Laird NanoBlue-IP04	PCB Dipole	UFL	2	---	---	---	-
6	Ethertronics WLAN_1000146	PIFA	UFL	2.5	3.5	3.5	3.5	3.5

### 1.1.3 EUT Operational Condition

<b>Supply Voltage</b>	<input type="checkbox"/> AC mains	<input checked="" type="checkbox"/> DC (3.3 / 1.8Vdc)	
<b>Type of DC Source</b>	<input type="checkbox"/> Internal DC supply	<input type="checkbox"/> External DC adapter	<input checked="" type="checkbox"/> From Host

### 1.1.4 Accessories

N/A



### 1.1.5 Channel List

Frequency band (MHz)	
802.11 a / HT20	
Channel	Frequency(MHz)
149	5745
153	5765
157	5785
161	5805
165	5825

### 1.1.6 Test Tool and Duty Cycle

Test tool	VC_Example_windows_forms, ver. 1.3
Duty Cycle Of Test Signal (%)	99.59% - IEEE 802.11a 99.56% - IEEE 802.11n (HT20)
Duty Factor	0.02 - IEEE 802.11a 0.02 - IEEE 802.11n (HT20)

### 1.1.7 Power Setting

Modulation Mode	Test Frequency (MHz)		
	a / n HT20		
	5745	5785	5825
a	20	20	20
n (HT20)	20	20	20



## 1.2 Test Setup Chart

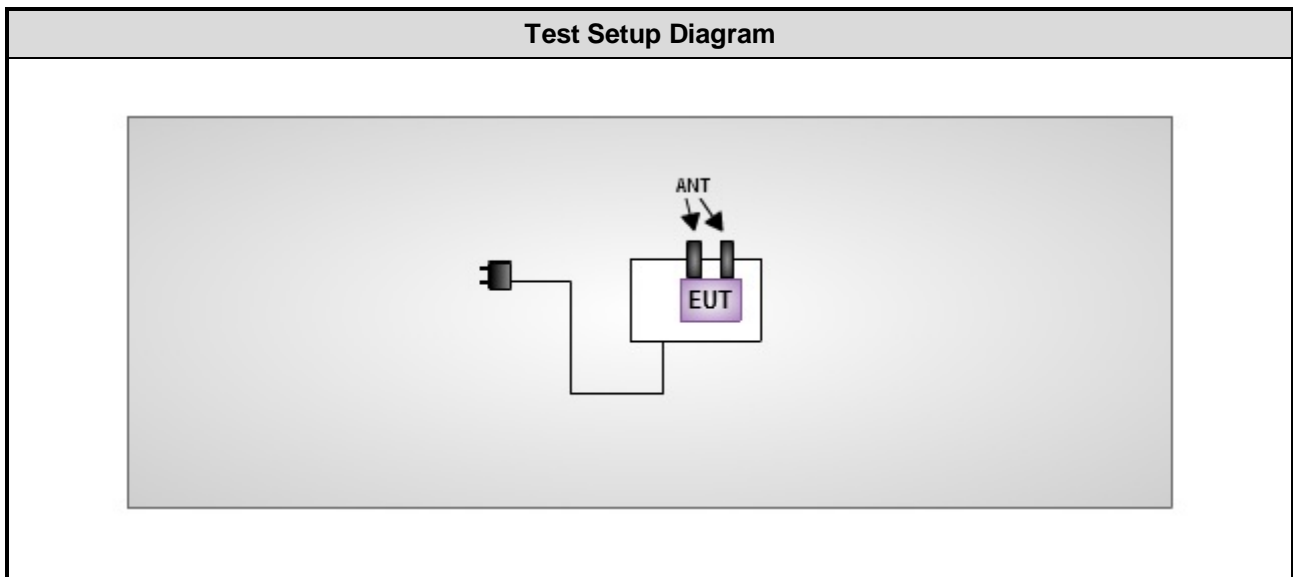



### 1.3 The Equipment List

<b>Test Item</b>	Conducted Emission				
<b>Test Site</b>	Conduction room 1 / (CO01-WS)				
<b>Instrument</b>	<b>Manufacturer</b>	<b>Model No.</b>	<b>Serial No.</b>	<b>Calibration Date</b>	<b>Calibration Until</b>
EMC Receiver	R&S	ESCS 30	100169	Dec. 12, 2012	Dec. 11, 2013
LISN	SCHWARZBECK MESS-ELEKTRONIK	Schwarzbeck 8127	8127-667	Dec. 04, 2012	Dec. 03, 2013
LISN (Support Unit)	SCHWARZBECK MESS-ELEKTRONIK	Schwarzbeck 8127	8127-666	Dec. 04, 2012	Dec. 03, 2013
ISN	TESEQ	ISN T800	34406	Apr. 08, 2013	Apr. 07, 2014
ISN	TESEQ	ISN T200A	30494	Apr. 09, 2013	Apr. 08, 2014
ISN	TESEQ	ISN T8-Cat6	27262	Sep. 17, 2012	Sep. 16, 2013
ISN	TESEQ	ISN ST08	22589	Jan. 24, 2013	Jan. 23, 2014
RF Current Probe	FCC	F-33-4	121630	Dec. 04, 2012	Dec. 03, 2013
RF Cable-CON	Woken	CFD200-NL	CFD200-NL-001	Dec. 25, 2012	Dec. 24, 2013
ESH3-Z6 V-Network(+)	R&S	ESH3-Z6	100920	Nov. 21, 2012	Nov. 20, 2013
ESH3-Z6 V-Network(-)	R&S	ESH3-Z6	100951	Jan. 03, 2013	Jan. 02, 2014
Two-Line V-Network	R&S	ENV216	101579	Jan. 07, 2013	Jan. 06, 2014
50 ohm terminal	NA	50	01	Apr. 22, 2013	Apr. 21, 2014
50 ohm terminal	NA	50	02	Apr. 22, 2013	Apr. 21, 2014
50 ohm terminal	NA	50	03	Apr. 22, 2013	Apr. 21, 2014
50 ohm terminal (Support Unit)	NA	50	04	Apr. 22, 2013	Apr. 21, 2014
Note: Calibration Interval of instruments listed above is one year.					





<b>Test Item</b>	Radiated Emission above 1GHz				
<b>Test Site</b>	966 chamber1 / (03CH01-WS)				
<b>Instrument</b>	<b>Manufacturer</b>	<b>Model No.</b>	<b>Serial No.</b>	<b>Calibration Date</b>	<b>Calibration Until</b>
3m semi-anechoic chamber	CHAMPRO	SAC-03	03CH01-WS	Jan. 04, 2013	Jan. 03, 2014
Spectrum Analyzer	R&S	FSV40	101498	Jan. 24, 2013	Jan. 23, 2014
Receiver	ROHDE&SCHWARZ	ESR3	101658	Jan. 28, 2013	Jan. 27, 2014
Bilog Antenna	SCHWARZBECK	VULB9168	VULB9168-522	Jan. 11, 2013	Jan. 10, 2014
Horn Antenna 1G-18G	SCHWARZBECK	BBHA 9120 D	BBHA 9120 D 1096	Feb. 18, 2013	Feb. 17, 2014
Horn Antenna 18G-40G	SCHWARZBECK	BBHA 9170	BBHA 9170517	Jan. 14, 2013	Jan. 13, 2014
Amplifier	Burgeon	BPA-530	100219	Nov. 28, 2012	Nov. 27, 2013
Amplifier	Agilent	83017A	MY39501308	Dec. 18, 2012	Dec. 17, 2013
RF Cable	HUBER+SUHNER	SUCOFLEX104	MY16014/4	Dec. 25, 2012	Dec. 24, 2013
RF Cable	HUBER+SUHNER	SUCOFLEX104	MY16019/4	Dec. 25, 2012	Dec. 24, 2013
RF Cable	HUBER+SUHNER	SUCOFLEX104	MY16139/4	Dec. 25, 2012	Dec. 24, 2013
RF Cable-R03m	Woken	CFD400NL-LW	CFD400NL-001	Dec. 25, 2012	Dec. 24, 2013
RF Cable-R10m	Woken	CFD400NL-LW	CFD400NL-002	Dec. 25, 2012	Dec. 24, 2013
control	EM Electronics	EM1000	60612	N/A	N/A
Note: Calibration Interval of instruments listed above is one year.					

Loop Antenna	R&S	HFH2-Z2	100330	Nov. 15, 2012	Nov. 14, 2014
Amplifier	MITEQ	AMF-6F-260400	9121372	Apr. 19, 2013	Apr. 18, 2015
Note: Calibration Interval of instruments listed above is two year.					



Test Item	RF Conducted				
Test Site	(TH01-WS)				
Instrument	Manufacturer	Model No.	Serial No.	Calibration Date	Calibration Until
Spectrum Analyzer	R&S	FSV 40	101063	Feb. 18, 2013	Feb. 17, 2014
TEMP&HUMIDITY CHAMBER	GIANT FORCE	GCT-225-40-SP-SD	MAF1212-002	Nov. 29, 2012	Nov. 28, 2013
Power Meter	Anritsu	ML2495A	1241002	Oct. 15, 2012	Oct. 14, 2013
Power Sensor	Anritsu	MA2411B	1027366	Oct. 24, 2012	Oct. 23, 2013
Signal Generator	R&S	SMB100A	175727	Jan. 14, 2013	Jan. 13, 2014
Radio Communication Analyzer	Anritsu	MT8820C	6201240341	Mar. 13, 2013	Mar. 12, 2014
Wideband Radio Communication Tester	R&S	CMW500	106070	Jan. 29, 2013	Jan. 28, 2014
Bluetooth Tester	R&S	CBT	100959	Jan. 09, 2013	Jan. 08, 2014
MXG-B RF Vector Signal Generator	Agilent	N5182B	MY53050081	Apr. 19, 2013	Apr. 18, 2014

Note: Calibration Interval of instruments listed above is one year.



## 1.4 Test Standards

According to the specification of EUT, the EUT must comply with following standards and KDB documents.

RSS-210 Issue 8 December 2010

RSS-Gen Issue 3 December 2010

ANSI C63.10-2009

FCC KDB 558074 D01 DTS Meas Guidance v03

## 1.5 Measurement Uncertainty

ISO/IEC 17025 requires that an estimate of the measurement uncertainties associated with the emissions test results be included in the report. The measurement uncertainties given below are based on a 95% confidence level (based on a coverage factor (k=2))

Measurement Uncertainty	
Parameters	Uncertainty
Bandwidth	±35.286 Hz
Conducted power	±0.536 dB
Frequency error	±35.286 Hz
Temperature	±0.3 °C
Conducted emission	±2.946 dB
AC conducted emission	±2.43 dB
Radiated emission	±2.49 dB



## 2 Test Configuration

### 2.1 Testing Condition

Test Item	Test Site	Ambient Condition	Tested By
AC Conduction	CO01-WS	23°C / 55%	Skys Huang
Radiated Emissions	03CH01-WS	24°C / 63%	Aska Huang Haru Yang
RF Conducted	TH01-WS	21°C / 60%	Brad Wu

➤ FCC site registration No.: 657002

➤ IC site registration No.: 10807A-1

### 2.2 The Worst Test Modes and Channel Details

Test item	Mode	Test Frequency (MHz)	Data rate (Mbps)	Test Configuration
Conducted Emissions	11a	5825	6	1
Radiated Emissions (below 1GHz)	11a	5825	6	1, 2, 3
Radiated Emissions (above 1GHz)	11a HT20	5745 / 5785 / 5825 5745 / 5785 / 5825	6 MCS 0	1, 2, 3
Fundamental Emission Output Power	11a HT20	5745 / 5785 / 5825 5745 / 5785 / 5825	6 MCS 0	1
6dB bandwidth				
Power spectral density				

**NOTE:**

- The EUT was pretested with 3 orientations placed on the table for the radiated emission measurement – X, Y, and Z-plane. The **Y-plane** results were found as the worst case and were shown in this report.
- 3 types antenna are used for this device, highest gain antenna of each type is selected to perform radiated emission test as below test configuration
  - Configuration 1 : Dipole antenna (Antenna No.1) , Y-plane
  - Configuration 2 : PCB Dipole antenna (Antenna No.3) , Y-plane
  - Configuration 3 : PIFA antenna (Antenna No.6), Y-plane
- The EUT supports two DC voltage options, 3.3Vdc and 1.8Vdc. Both options were assessed and 3.3Vdc was found to be the worst case and was selected for the final test.



### 3 Transmitter Test Results

#### 3.1 Conducted Emissions

##### 3.1.1 Limit of Conducted Emissions

AC Power-line Conducted Emissions Limit		
Frequency Emission (MHz)	Quasi-Peak	Average
0.15-0.5	66 - 56 *	56 - 46 *
0.5-5	56	46
5-30	60	50

Note 1: \* Decreases with the logarithm of the frequency.

##### 3.1.2 Test Procedures

1. The device is placed on a test table, raised 80 cm above the reference ground plane. The vertical conducting plane is located 40 cm to the rear of the device.
2. The device is connected to line impedance stabilization network (LISN) and other accessories are connected to other LISN. Measured levels of AC power line conducted emission are across the 50 Ω LISN port.
3. AC conducted emission measurements is made over frequency range from 150 kHz to 30 MHz.

##### 3.1.3 Test Setup

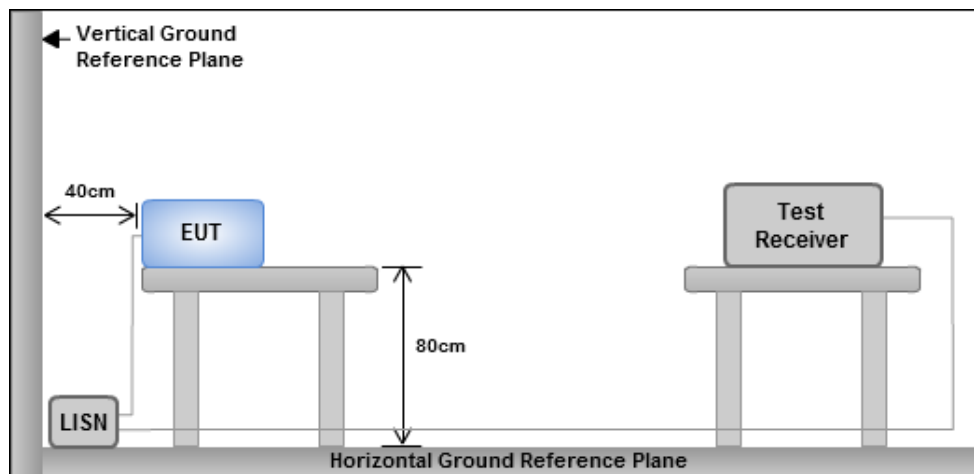

- Note: 1. Support units were connected to second LISN.  
2. Both of LISNs (AMN) are 80 cm from EUT and at least 80 cm from other units and other metal planes



### 3.1.4 Test Result of Conducted Emissions

<b>Modulation Mode</b>	11a	<b>Test Freq. (MHz)</b>	5825
<b>Power Phase</b>	Line	<b>Test Configuration</b>	1

Date: 2013-06-03

	Freq	Level	Limit	Over	Read	LISN	cable	Remark
	MHz	dBuV	Line	Limit	Level	factor	loss	
			dBuV	dB	dBuV	dB	dB	
1	0.158	26.04	55.56	-29.52	25.93	0.03	0.08	Average
2	0.158	49.85	65.56	-15.71	49.74	0.03	0.08	QP
3	0.202	30.17	53.54	-23.37	29.96	0.03	0.18	Average
4	0.202	46.05	63.54	-17.49	45.84	0.03	0.18	QP
5	0.391	22.10	48.03	-25.93	22.02	0.03	0.05	Average
6	0.391	33.75	58.03	-24.28	33.67	0.03	0.05	QP
7	1.111	12.82	46.00	-33.18	12.72	0.04	0.06	Average
8	1.111	26.34	56.00	-29.66	26.24	0.04	0.06	QP
9	4.269	14.62	46.00	-31.38	14.33	0.06	0.23	Average
10	4.269	28.83	56.00	-27.17	28.54	0.06	0.23	QP
11	6.841	15.89	50.00	-34.11	15.65	0.08	0.16	Average
12	6.841	28.84	60.00	-31.16	28.60	0.08	0.16	QP

Note 1: Level (dBUV) = Read Level (dBUV) + LISN Factor (dB) + Cable Loss (dB).  
 Note 2: Over Limit (dBUV) = Limit Line (dBUV) – Level (dBUV).



<b>Modulation Mode</b>	11a	<b>Test Freq. (MHz)</b>	5825
<b>Power Phase</b>	Neutral	<b>Test Configuration</b>	1

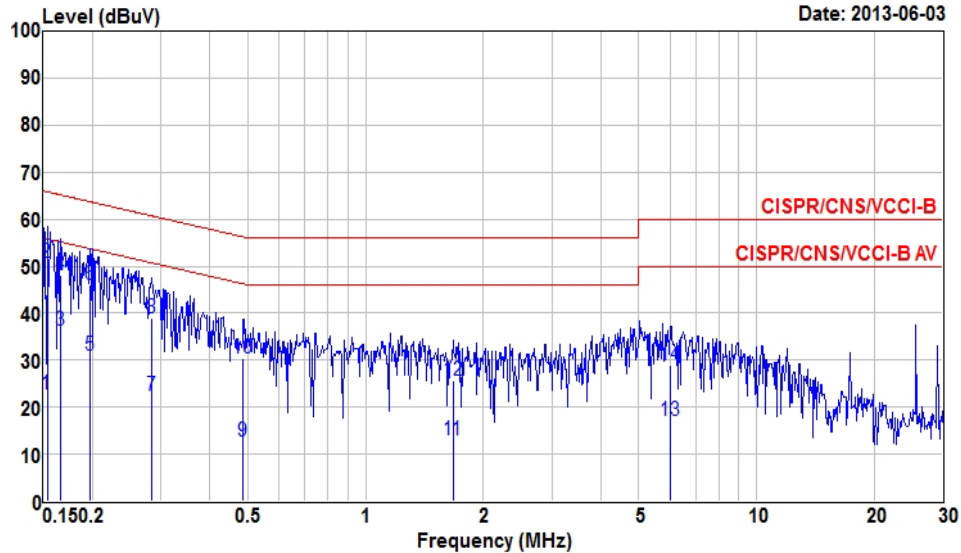

	Freq MHz	Level dBuV	Limit Line dBuV	Over Limit dB	Read Level dBuV	LISN factor dB	cable loss dB	Remark
1	0.153	22.79	55.82	-33.03	22.70	0.02	0.07	Average
2	0.153	50.72	65.82	-15.10	50.63	0.02	0.07	QP
3	0.166	36.21	55.16	-18.95	36.09	0.02	0.10	Average
4	0.166	48.08	65.16	-17.08	47.96	0.02	0.10	QP
5	0.198	30.89	53.71	-22.82	30.69	0.02	0.18	Average
6	0.198	46.05	63.71	-17.66	45.85	0.02	0.18	QP
7	0.283	22.55	50.72	-28.17	22.42	0.02	0.11	Average
8	0.283	39.04	60.72	-21.68	38.91	0.02	0.11	QP
9	0.486	12.57	46.23	-33.66	12.50	0.02	0.05	Average
10	0.486	30.48	56.23	-25.75	30.41	0.02	0.05	QP
11	1.671	12.88	46.00	-33.12	12.72	0.03	0.13	Average
12	1.671	25.78	56.00	-30.22	25.62	0.03	0.13	QP
13	6.024	17.14	50.00	-32.86	16.90	0.06	0.18	Average
14	6.024	28.85	60.00	-31.15	28.61	0.06	0.18	QP

Note 1: Level (dBuV) = Read Level (dBuV) + LISN Factor (dB) + Cable Loss (dB).  
 2: Over Limit (dBuV) = Limit Line (dBuV) – Level (dBuV).



## 3.2 6dB and Occupied Bandwidth

### 3.2.1 Limit of 6dB Bandwidth

The minimum 6dB bandwidth shall be at least 500 kHz.

### 3.2.2 Test Procedures

1. Set resolution bandwidth (RBW) = 100 kHz, Video bandwidth = 300 kHz.
2. Detector = Peak, Trace mode = max hold.
3. Sweep = auto couple, Allow the trace to stabilize.
4. Measure the maximum width of the emission that is constrained by the frequencies associated with the two outermost amplitude points (upper and lower) that are attenuated by 6dB relative to the maximum level measured in the fundamental emission.

### 3.2.3 Test Setup

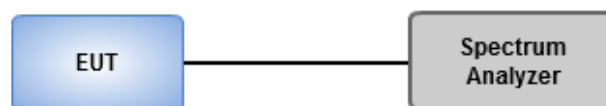





### 3.2.4 Test Result of 6dB and Occupied Bandwidth

Modulation Mode	N <sub>TX</sub>	Freq. (MHz)	6dB Bandwidth (MHz)				Limit (kHz)
			Chain 0	Chain 1	Chain 2	Chain 3	
11a	1	5745	15.71	---	---	---	500
11a	1	5785	15.36	---	---	---	500
11a	1	5825	15.25	---	---	---	500
HT20	1	5745	16.87	---	---	---	500
HT20	1	5785	15.94	---	---	---	500
HT20	1	5825	16.00	---	---	---	500

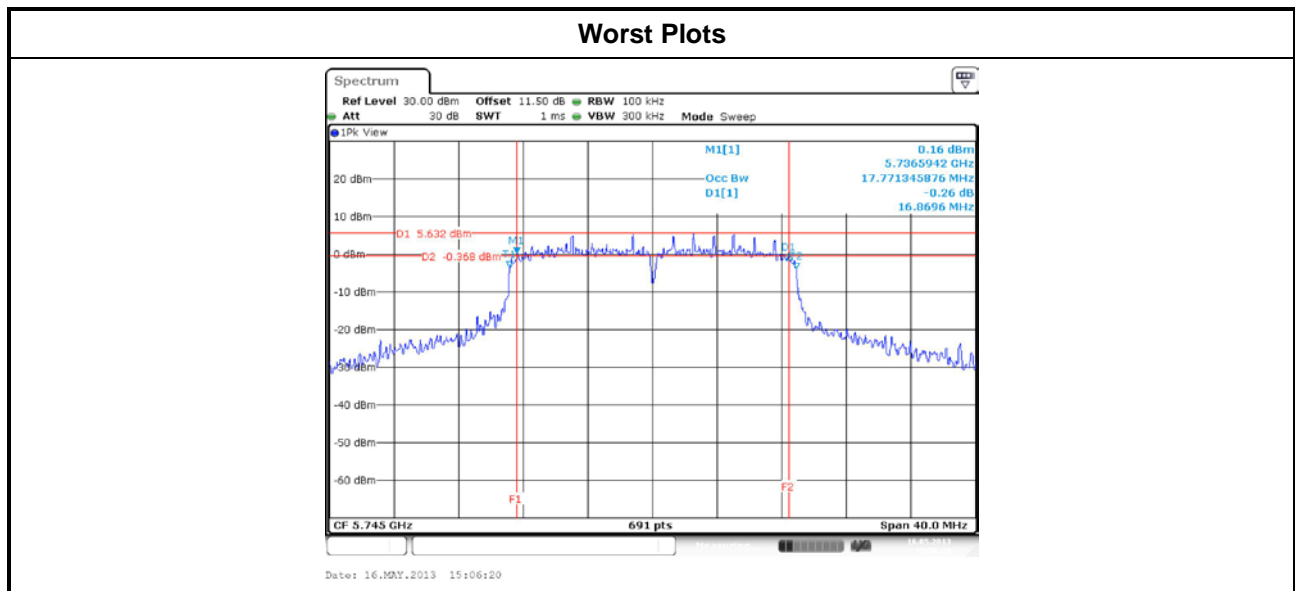



Modulation Mode	Freq. (MHz)	99% Occupied Bandwidth (MHz)			
		Chain 0	Chain 1	Chain 2	Chain 3
11a	5745	17.02	---	---	---
11a	5785	18.06	---	---	---
11a	5825	19.91	---	---	---
HT20	5745	18.29	---	---	---
HT20	5785	20.14	---	---	---
HT20	5825	21.07	---	---	---

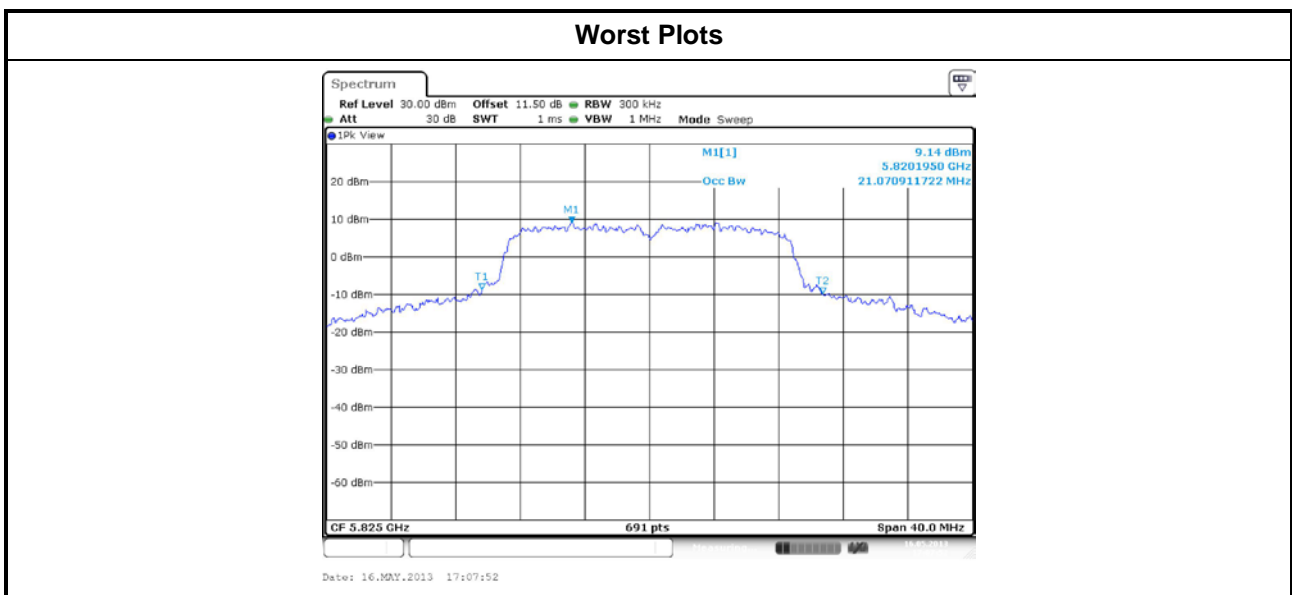



### 3.3 RF Output Power

#### 3.3.1 Limit of RF Output Power

Conducted power shall not exceed 1Watt.

- Antenna gain  $\leq$  6dBi, no any corresponding reduction is in output power limit.
- Antenna gain  $>$  6dBi
  - Non Fixed, point to point operations.  
The conducted output power from the intentional radiator shall be reduced by the amount in dB that the directional gain of the antenna exceeds 6 dB
  - Fixed, point to point operations  
Systems operating in the 2400–2483.5 MHz band that are used exclusively for fixed, point-to-point Operations, maximum peak output power of the intentional radiator is reduced by 1 dB for every 3 dB that the directional gain of the antenna exceeds 6 dBi.

Systems operating in the 5725–5850 MHz band that are used exclusively for fixed, point-to-point operations ,no any corresponding reduction is in transmitter peak output power

#### 3.3.2 Test Procedures

- Maximum Peak Conducted Output Power
  - Spectrum analyzer**
    1. Set RBW = 1MHz, VBW = 3MHz, Detector = Peak.
    2. Sweep time = auto, Trace mode = max hold, Allow trace to fully stabilize.
    3. Use the spectrum analyzer channel power measurement function with the band limits set equal to the DTS bandwidth edges.
  - Power meter**
    1. A broadband Peak RF power meter is used for output power measurement. The video bandwidth of power meter is greater than 6dB bandwidth of EUT. If duty cycle of test signal is not 100 %, trigger and gating function of power meter will be enabled to capture transmission burst for measuring output power.
- Maximum Conducted Output Power
  - Spectrum analyzer**
    1. Set RBW = 1MHz, VBW = 3MHz, Detector = RMS.
    2. Set the sweep time to:  $\geq 10 \times$  (number of measurement points in sweep)  $\times$  (maximum data rate per stream).
    3. Perform the measurement over a single sweep.
    4. Use the spectrum analyzer's band power measurement function with band limits set equal to the EBW(26dBc) band edges.
  - Power meter**
    1. A broadband Average RF power meter is used for output power measurement. The video bandwidth of power meter is greater than 6dB bandwidth of EUT. If duty cycle of test signal is not 100 %, trigger and gating function of power meter will be enabled to capture transmission burst for measuring output power.



### 3.3.3 Test Setup



### 3.3.4 Test Result of Maximum Output Power

Modulation Mode	N <sub>TX</sub>	Freq. (MHz)	Peak Power (dBm)				Total Power (mW)	Total Power (dBm)	Limit (dBm)
			Chain 0	Chain 1	Chain 2	Chain 3			
11a	1	5745	24.04	---	---	---	253.51	24.04	30
11a	1	5785	24.16	---	---	---	260.62	24.16	30
11a	1	5825	24.23	---	---	---	264.85	24.23	30
HT20	1	5745	24.03	---	---	---	252.93	24.03	30
HT20	1	5785	24.12	---	---	---	258.23	24.12	30
HT20	1	5825	24.13	---	---	---	258.82	24.13	30

Modulation Mode	N <sub>TX</sub>	Freq. (MHz)	Conducted (average) output power (dBm)				Total Power (mW)	Total Power (dBm)	Limit (dBm)
			Chain 0	Chain 1	Chain 2	Chain 3			
11a	1	5745	18.17	---	---	---	65.61	18.17	30
11a	1	5785	18.71	---	---	---	74.30	18.71	30
11a	1	5825	19.09	---	---	---	81.10	19.09	30
HT20	1	5745	18.15	---	---	---	65.31	18.15	30
HT20	1	5785	18.72	---	---	---	74.47	18.72	30
HT20	1	5825	18.94	---	---	---	78.34	18.94	30

Note: Conducted average output power is for reference only.



### 3.4 Power Spectral Density

#### 3.4.1 Limit of Power Spectral Density

Power spectral density shall not be greater than 8 dBm in any 3 kHz band.

#### 3.4.2 Test Procedures

- Maximum peak conducted output power was used to demonstrate compliance to the fundamental output power limit.
  1. Set the RBW = 100kHz, VBW = 300kHz.
  2. Detector = Peak, Sweep time = auto couple.
  3. Trace mode = max hold, allow trace to fully stabilize.
  4. Use the peak marker function to determine the maximum amplitude level.
- Maximum (average) conducted output power was used to demonstrate compliance to the fundamental output power limit.
  1. Set the RBW = 100kHz, VBW = 300 kHz.
  2. Detector = RMS, Sweep time = auto couple.
  3. Set the sweep time to:  $\geq 10 \times (\text{number of measurement points in sweep}) \times (\text{maximum data rate per stream})$ .
  4. Perform the measurement over a single sweep.
  5. Use the peak marker function to determine the maximum amplitude level.\

#### 3.4.3 Test Setup

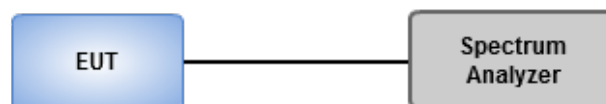



### 3.4.4 Test Result of Power Spectral Density

Modulation Mode	N <sub>TX</sub>	Freq. (MHz)	Total Power Spectral Density (dBm/30kHz)	Limit (dBm/3kHz)
11a	1	5745	0.06	8
11a	1	5785	1.22	8
11a	1	5825	1.88	8
HT20	1	5745	0.46	8
HT20	1	5785	1.95	8
HT20	1	5825	2.21	8

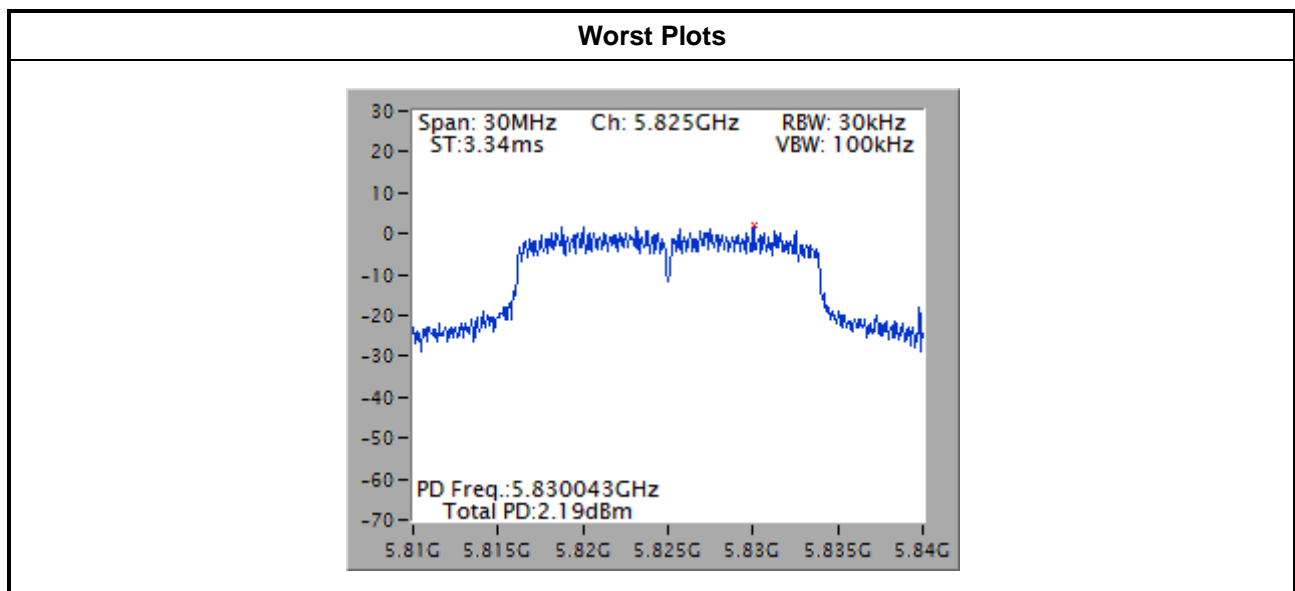

Note: Power density plot without duty factor



### 3.5 Unwanted Emissions into Restricted Frequency Bands

#### 3.5.1 Limit of Unwanted Emissions into Restricted Frequency Bands

Restricted Band Emissions Limit			
Frequency Range (MHz)	Field Strength (uV/m)	Field Strength (dBuV/m)	Measure Distance (m)
0.009~0.490	2400/F(kHz)	48.5 - 13.8	300
0.490~1.705	24000/F(kHz)	33.8 - 23	30
1.705~30.0	30	29	30
30~88	100	40	3
88~216	150	43.5	3
216~960	200	46	3
Above 960	500	54	3

**Note 1:**  
 Qusai-Peak value is measured for frequency below 1GHz except for 9–90 kHz, 110–490 kHz frequency band. Peak and average value are measured for frequency above 1GHz. The limit on average radio frequency emission is as above table. The limit on peak radio frequency emissions is 20 dB above the maximum permitted average emission limit

**Note 2:**  
 Measurements may be performed at a distance other than what is specified provided. When performing measurements at a distance other than that specified, the results shall be extrapolated to the specified distance using an extrapolation factor as below, Frequency at or above 30 MHz: 20 dB/decade Frequency below 30 MHz: 40 dB/decade.

#### 3.5.2 Test Procedures

1. Measurement is made at a semi-anechoic chamber that incorporates a turntable allowing a EUT rotation of 360°. A continuously-rotating, remotely-controlled turntable is installed at the test site to support the EUT and facilitate determination of the direction of maximum radiation for each EUT emission frequency. The EUT is placed at a height of 0.8 m test table above the ground plane.
2. Measurement is made with the antenna positioned in both the horizontal and vertical planes of polarization. The measurement antenna is varied in height (1m ~ 4m) above the reference ground plane to obtain the maximum signal strength. Distance between EUT and antenna is 3 m.
3. This investigation is performed with the EUT rotated 360°, the antenna height scanned between 1 m and 4 m, and the antenna rotated to repeat the measurements for both the horizontal and vertical antenna polarizations.

Note:

1. 120kHz measurement bandwidth of test receiver and Quasi-peak detector is for radiated emission below 1GHz.
2. RBW=1MHz, VBW=3MHz and Peak detector is for peak measured value of radiated emission above 1GHz.
3. RBW=1MHz, VBW=3MHz and RMS detector is for average measured value of radiated emission above 1GHz.



### 3.5.3 Test Setup

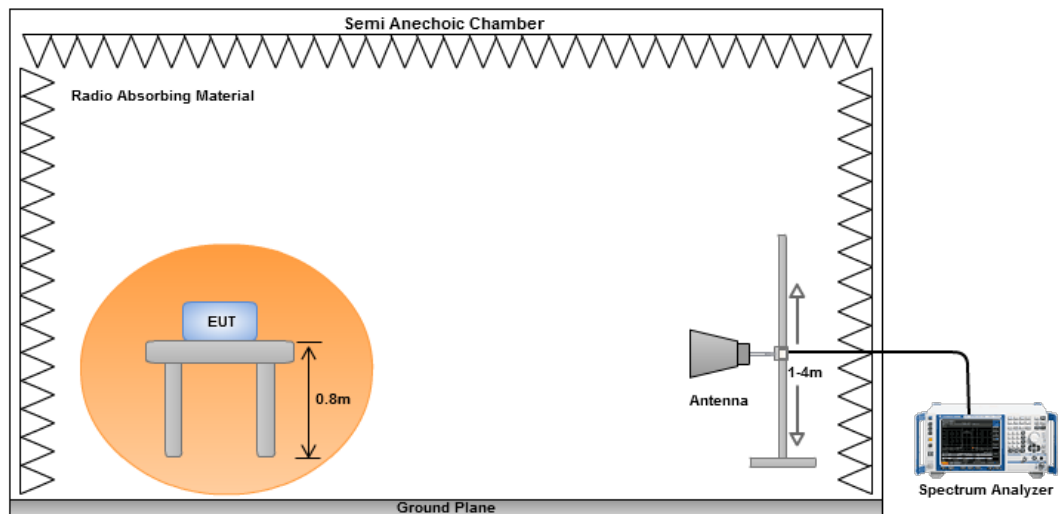





### 3.5.4 Transmitter Radiated Unwanted Emissions (Below 1GHz)

Modulation Mode	11a	Test Freq. (MHz)	5825
Polarization	Horizontal	Test Configuration	1

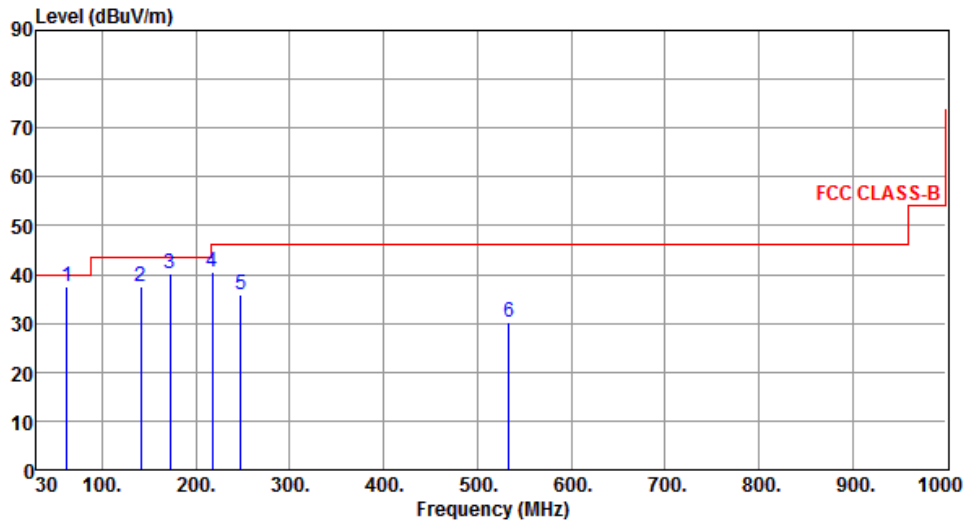

	Freq. MHz	Emission level dBuV/m	Limit dBuV/m	Margin dB	SA reading dBuV	Factor dB	Remark	ANT High cm	Turn Table deg
1	62.13	37.69	40.00	-2.31	55.40	-17.71	Peak	---	---
2	140.94	37.63	43.50	-5.87	54.80	-17.17	Peak	---	---
3	172.65	40.26	43.50	-3.24	57.74	-17.48	Peak	---	---
4	217.29	40.37	46.00	-5.63	59.76	-19.39	Peak	---	---
5	247.50	35.94	46.00	-10.06	53.88	-17.94	Peak	---	---
6	533.74	30.15	46.00	-15.85	41.14	-10.99	Peak	---	---

Note 1: Level (dBuV/m) = Read Level (dBuV/m) + Antenna Factor (dB) + Cable Loss (dB) - Preamp Factor (dB).  
 2: Over Limit (dBuV/m) = Limit Line (dBuV/m) – Level (dBuV/m).



<b>Modulation Mode</b>	11a	<b>Test Freq. (MHz)</b>	5825
<b>Polarization</b>	Vertical	<b>Test Configuration</b>	1

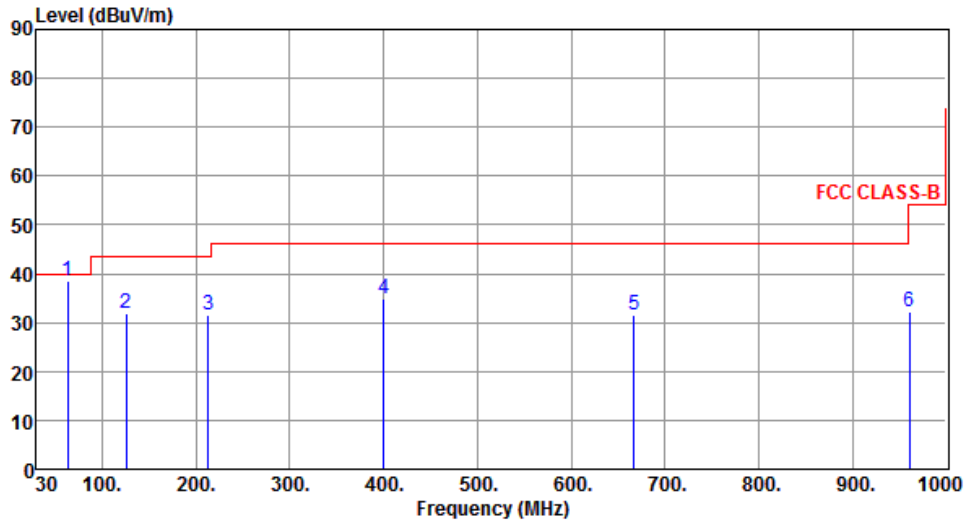

	Freq. MHz	Emission level dBuV/m	Limit dBuV/m	Margin dB	SA reading dBuV	Factor dB	Remark	ANT High cm	Turn Table deg
1	62.83	38.41	40.00	-1.59	56.26	-17.85	QP	---	---
2	125.46	31.75	43.50	-11.75	50.33	-18.58	Peak	---	---
3	213.27	31.48	43.50	-12.02	50.88	-19.40	Peak	---	---
4	400.11	34.85	46.00	-11.15	48.51	-13.66	Peak	---	---
5	667.38	31.65	46.00	-14.35	40.40	-8.75	Peak	---	---
6	960.59	32.16	54.00	-21.84	36.92	-4.76	Peak	---	---

Note 1: Level (dBuV/m) = Read Level (dBuV/m) + Antenna Factor (dB) + Cable Loss (dB) - Preamp Factor (dB).  
 2: Over Limit (dBuV/m) = Limit Line (dBuV/m) – Level (dBuV/m).



<b>Modulation Mode</b>	11a	<b>Test Freq. (MHz)</b>	5825
<b>Polarization</b>	Horizontal	<b>Test Configuration</b>	2

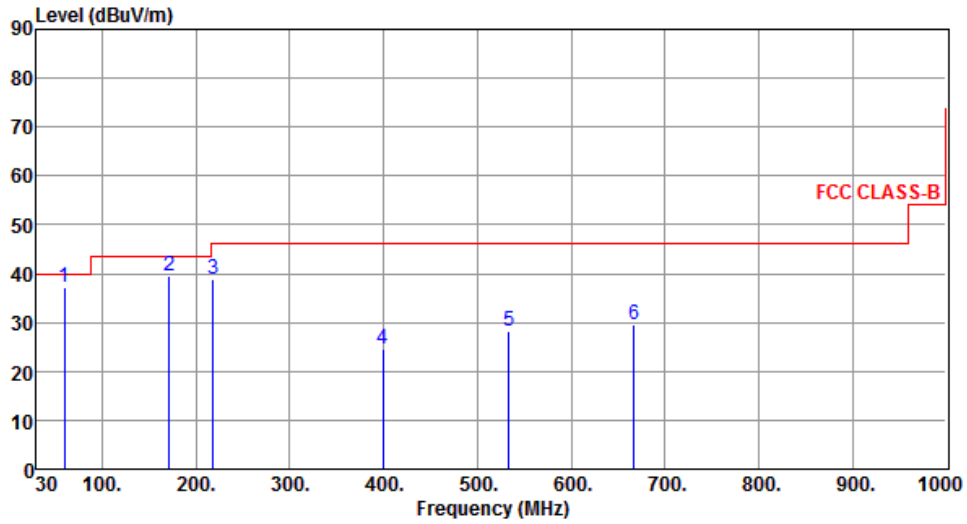

	Freq. MHz	Emission level dBuV/m	Limit dBuV/m	Margin dB	SA reading dBuV	Factor dB	Remark	ANT High cm	Turn Table deg
1	60.07	37.34	40.00	-2.66	54.65	-17.31	Peak	---	---
2	171.62	39.48	43.50	-4.02	56.85	-17.37	Peak	---	---
3	218.18	38.78	46.00	-7.22	58.17	-19.39	Peak	---	---
4	399.57	24.62	46.00	-21.38	38.29	-13.67	Peak	---	---
5	533.43	28.13	46.00	-17.87	39.12	-10.99	Peak	---	---
6	667.29	29.56	46.00	-16.44	38.32	-8.76	Peak	---	---

Note 1: Level (dBuV/m) = Read Level (dBuV/m) + Antenna Factor (dB) + Cable Loss (dB) - Preamp Factor (dB).  
 2: Over Limit (dBuV/m) = Limit Line (dBuV/m) – Level (dBuV/m).



<b>Modulation Mode</b>	11a	<b>Test Freq. (MHz)</b>	5825
<b>Polarization</b>	Vertical	<b>Test Configuration</b>	2

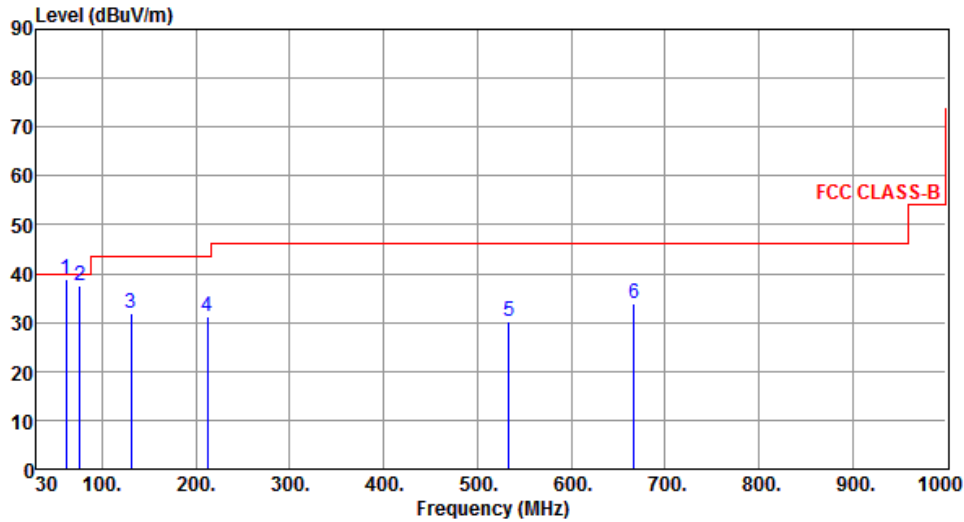

	Freq. MHz	Emission level dBuV/m	Limit dBuV/m	Margin dB	SA reading dBuV	Factor dB	Remark	ANT High cm	Turn Table deg
1	61.24	38.76	40.00	-1.24	56.30	-17.54	QP	---	---
2	76.56	37.58	40.00	-2.42	58.51	-20.93	Peak	---	---
3	130.88	31.91	43.50	-11.59	49.95	-18.04	Peak	---	---
4	212.36	31.28	43.50	-12.22	50.68	-19.40	Peak	---	---
5	533.43	30.26	46.00	-15.74	41.25	-10.99	Peak	---	---
6	667.29	33.78	46.00	-12.22	42.54	-8.76	Peak	---	---

Note 1: Level (dBuV/m) = Read Level (dBuV/m) + Antenna Factor (dB) + Cable Loss (dB) - Preamp Factor (dB).  
 2: Over Limit (dBuV/m) = Limit Line (dBuV/m) – Level (dBuV/m).



<b>Modulation Mode</b>	11a	<b>Test Freq. (MHz)</b>	5825
<b>Polarization</b>	Horizontal	<b>Test Configuration</b>	3

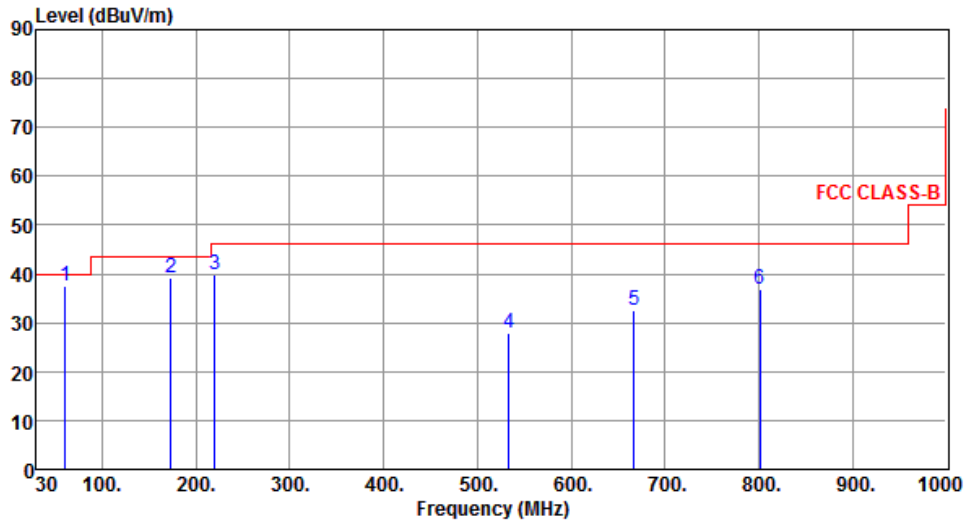

	Freq. MHz	Emission level dBuV/m	Limit dBuV/m	Margin dB	SA reading dBuV	Factor dB	Remark	ANT High cm	Turn Table deg
1	60.45	37.53	40.00	-2.47	54.92	-17.39	Peak	---	---
2	172.84	39.14	43.50	-4.36	56.64	-17.50	Peak	---	---
3	219.62	39.83	46.00	-6.17	59.21	-19.38	Peak	---	---
4	533.71	27.86	46.00	-18.14	38.85	-10.99	Peak	---	---
5	667.38	32.59	46.00	-13.41	41.34	-8.75	Peak	---	---
6	800.94	36.87	46.00	-9.13	43.62	-6.75	Peak	---	---

Note 1: Level (dBuV/m) = Read Level (dBuV/m) + Antenna Factor (dB) + Cable Loss (dB) - Preamp Factor (dB).  
 2: Over Limit (dBuV/m) = Limit Line (dBuV/m) – Level (dBuV/m).



<b>Modulation Mode</b>	11a	<b>Test Freq. (MHz)</b>	5825
<b>Polarization</b>	Vertical	<b>Test Configuration</b>	3

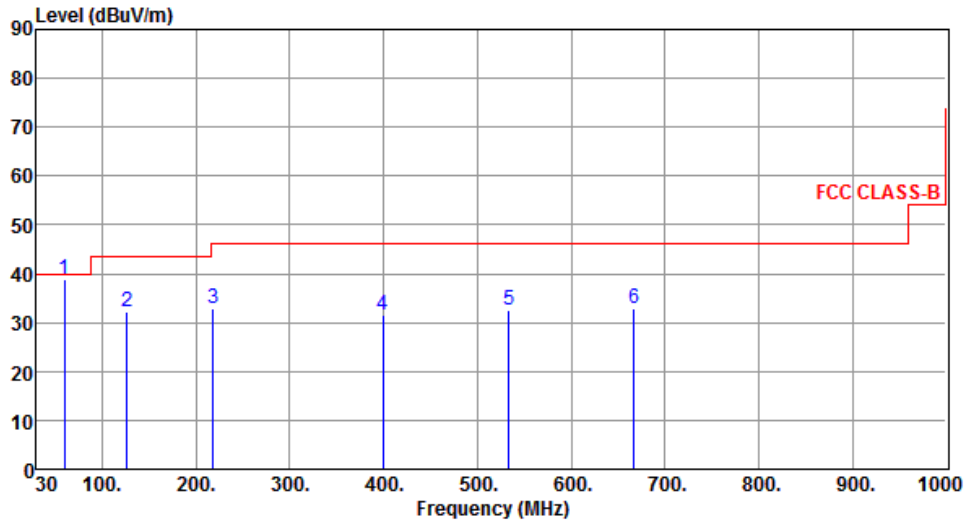

	Freq. MHz	Emission level dBuV/m	Limit dBuV/m	Margin dB	SA reading dBuV	Factor dB	Remark	ANT High cm	Turn Table deg
1	60.12	38.74	40.00	-1.26	56.06	-17.32	QP	---	---
2	126.85	32.26	43.50	-11.24	50.70	-18.44	Peak	---	---
3	218.29	32.76	46.00	-13.24	52.15	-19.39	Peak	---	---
4	399.27	31.48	46.00	-14.52	45.16	-13.68	Peak	---	---
5	533.67	32.39	46.00	-13.61	43.38	-10.99	Peak	---	---
6	667.42	32.83	46.00	-13.17	41.58	-8.75	Peak	---	---

Note 1: Level (dBuV/m) = Read Level (dBuV/m) + Antenna Factor (dB) + Cable Loss (dB) - Preamp Factor (dB).  
 2: Over Limit (dBuV/m) = Limit Line (dBuV/m) – Level (dBuV/m).



### 3.5.5 Transmitter Radiated Unwanted Emissions (Above 1GHz) for 11a

Polarization	Horizontal	Test Freq. (MHz)	5745						
Test Configuration	1								
	Freq.	Emission level	Limit	Margin	SA reading	Factor	Remark	ANT High	Turn Table
	MHz	dBuV/m	dBuV/m	dB	dBuV	dB		cm	deg
1	1050.00	35.26	54.00	-18.74	44.47	-9.21	Average	---	---
2	1050.00	46.58	74.00	-27.42	55.79	-9.21	Peak	---	---
3	7660.00	36.52	54.00	-17.48	26.89	9.63	Average	---	---
4	7660.00	49.80	74.00	-24.20	40.17	9.63	Peak	---	---
5	11490.00	44.79	54.00	-9.21	29.82	14.97	Average	---	---
6	11490.00	57.94	74.00	-16.06	42.97	14.97	Peak	---	---
<p>Note 1: "&gt;20dB" means spurious emission levels that exceed the level of 20 dB below the applicable limit.</p> <p>Note 2: For restricted bands, the peak measurement is fully sufficient, as the max field strength as measured with the Peak-Detector meets the AV-Limit so that the AV level does not need to be reported in addition.</p> <p>Note 3: For un-restricted bands, unwanted emissions shall be attenuated by at least 20 dB relative to the maximum measured in-band level.</p>									



<b>Polarization</b>	Vertical	<b>Test Freq. (MHz)</b>	5745
<b>Test Configuration</b>	1		

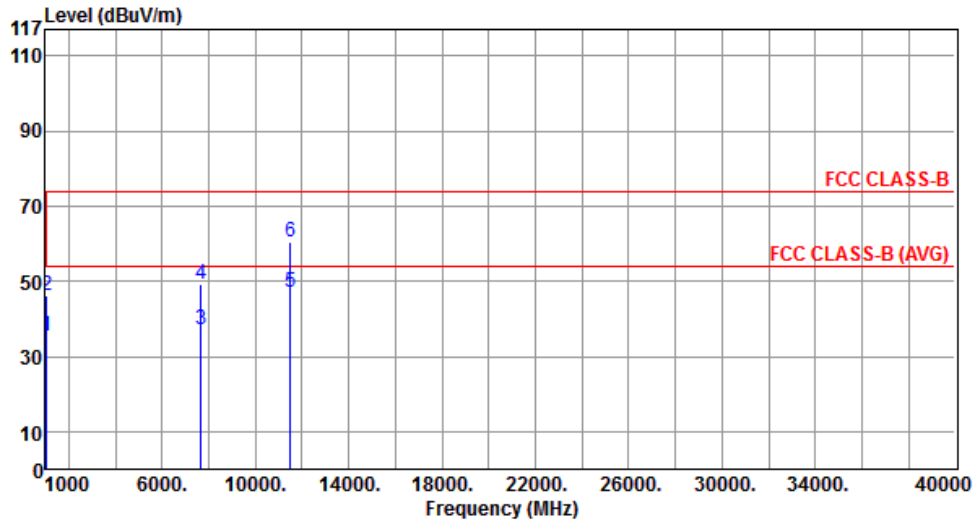

	Freq. MHz	Emission level dBuV/m	Limit dBuV/m	Margin dB	SA reading dBuV	Factor dB	Remark	ANT High cm	Turn Table deg
1	1050.00	35.22	54.00	-18.78	44.43	-9.21	Average	---	---
2	1050.00	46.38	74.00	-27.62	55.59	-9.21	Peak	---	---
3	7660.00	36.98	54.00	-17.02	27.35	9.63	Average	---	---
4	7660.00	49.42	74.00	-24.58	39.79	9.63	Peak	---	---
5	11490.00	47.02	54.00	-6.98	32.05	14.97	Average	---	---
6	11490.00	60.30	74.00	-13.70	45.33	14.97	Peak	---	---

Note 1: ">20dB" means spurious emission levels that exceed the level of 20 dB below the applicable limit.  
 Note 2: For restricted bands, the peak measurement is fully sufficient, as the max field strength as measured with the Peak-Detector meets the AV-Limit so that the AV level does not need to be reported in addition.  
 Note 3: For un-restricted bands, unwanted emissions shall be attenuated by at least 20 dB relative to the maximum measured in-band level.





<b>Polarization</b>	Horizontal	<b>Test Freq. (MHz)</b>	5785
<b>Test Configuration</b>	1		

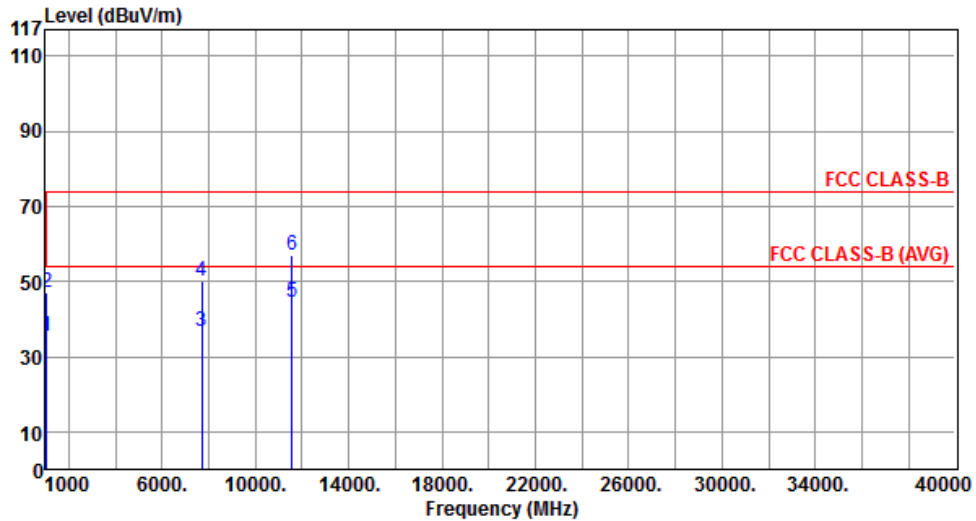

	Freq. MHz	Emission level dBuV/m	Limit dBuV/m	Margin dB	SA reading dBuV	Factor dB	Remark	ANT High cm	Turn Table deg
1	1050.00	35.21	54.00	-18.79	44.42	-9.21	Average	---	---
2	1050.00	46.89	74.00	-27.11	56.10	-9.21	Peak	---	---
3	7713.00	36.88	54.00	-17.12	27.21	9.67	Average	---	---
4	7713.00	50.02	74.00	-23.98	40.35	9.67	Peak	---	---
5	11570.00	44.40	54.00	-9.60	29.53	14.87	Average	---	---
6	11570.00	57.02	74.00	-16.98	42.15	14.87	Peak	---	---

Note 1: ">20dB" means spurious emission levels that exceed the level of 20 dB below the applicable limit.  
 Note 2: For restricted bands, the peak measurement is fully sufficient, as the max field strength as measured with the Peak-Detector meets the AV-Limit so that the AV level does not need to be reported in addition.  
 Note 3: For un-restricted bands, unwanted emissions shall be attenuated by at least 20 dB relative to the maximum measured in-band level.



<b>Polarization</b>	Vertical	<b>Test Freq. (MHz)</b>	5785
<b>Test Configuration</b>	1		

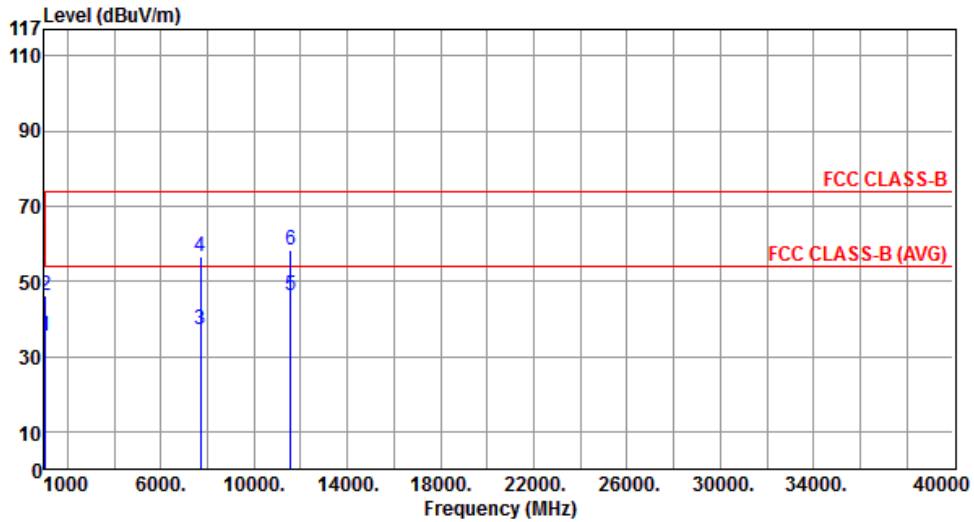

	Freq. MHz	Emission level dBuV/m	Limit dBuV/m	Margin dB	SA reading dBuV	Factor dB	Remark	ANT High cm	Turn Table deg
1	1050.00	35.44	54.00	-18.56	44.65	-9.21	Average	---	---
2	1050.00	46.34	74.00	-27.66	55.55	-9.21	Peak	---	---
3	7713.00	37.25	54.00	-16.75	27.58	9.67	Average	---	---
4	7713.00	56.36	74.00	-17.64	46.69	9.67	Peak	---	---
5	11570.00	46.05	54.00	-7.95	31.18	14.87	Average	---	---
6	11570.00	58.48	74.00	-15.52	43.61	14.87	Peak	---	---

Note 1: ">20dB" means spurious emission levels that exceed the level of 20 dB below the applicable limit.  
 Note 2: For restricted bands, the peak measurement is fully sufficient, as the max field strength as measured with the Peak-Detector meets the AV-Limit so that the AV level does not need to be reported in addition.  
 Note 3: For un-restricted bands, unwanted emissions shall be attenuated by at least 20 dB relative to the maximum measured in-band level.



<b>Polarization</b>	Horizontal	<b>Test Freq. (MHz)</b>	5825
<b>Test Configuration</b>	1		

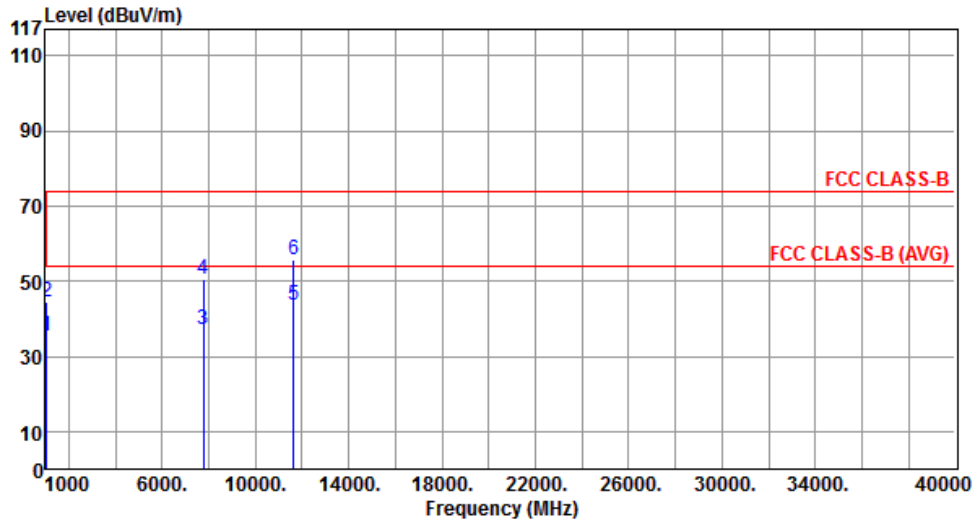

	Freq. MHz	Emission level dBuV/m	Limit dBuV/m	Margin dB	SA reading dBuV	Factor dB	Remark	ANT High cm	Turn Table deg
1	1050.00	35.26	54.00	-18.74	44.47	-9.21	Average	---	---
2	1050.00	44.39	74.00	-29.61	53.60	-9.21	Peak	---	---
3	7766.33	36.95	54.00	-17.05	27.24	9.71	Average	---	---
4	7766.33	50.48	74.00	-23.52	40.77	9.71	Peak	---	---
5	11650.00	43.44	54.00	-10.56	28.68	14.76	Average	---	---
6	11650.00	55.86	74.00	-18.14	41.10	14.76	Peak	---	---

Note 1: ">20dB" means spurious emission levels that exceed the level of 20 dB below the applicable limit.  
 Note 2: For restricted bands, the peak measurement is fully sufficient, as the max field strength as measured with the Peak-Detector meets the AV-Limit so that the AV level does not need to be reported in addition.  
 Note 3: For un-restricted bands, unwanted emissions shall be attenuated by at least 20 dB relative to the maximum measured in-band level.



<b>Polarization</b>	Vertical	<b>Test Freq. (MHz)</b>	5825
<b>Test Configuration</b>	1		

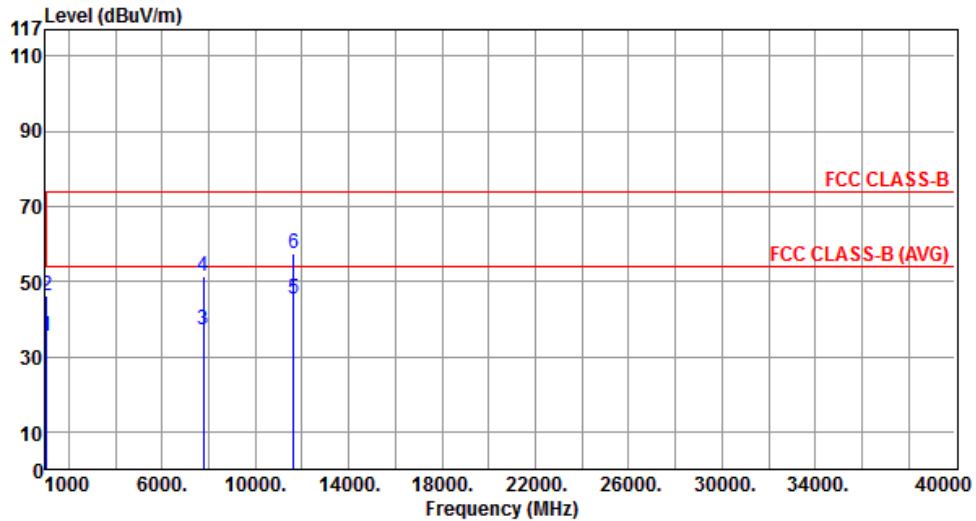

	Freq. MHz	Emission level dBuV/m	Limit dBuV/m	Margin dB	SA reading dBuV	Factor dB	Remark	ANT High cm	Turn Table deg
1	1050.00	35.31	54.00	-18.69	44.52	-9.21	Average	---	---
2	1050.00	46.27	74.00	-27.73	55.48	-9.21	Peak	---	---
3	7766.33	37.06	54.00	-16.94	27.35	9.71	Average	---	---
4	7766.33	51.18	74.00	-22.82	41.47	9.71	Peak	---	---
5	11650.00	45.12	54.00	-8.88	30.36	14.76	Average	---	---
6	11650.00	57.24	74.00	-16.76	42.48	14.76	Peak	---	---

Note 1: ">20dB" means spurious emission levels that exceed the level of 20 dB below the applicable limit.  
 Note 2: For restricted bands, the peak measurement is fully sufficient, as the max field strength as measured with the Peak-Detector meets the AV-Limit so that the AV level does not need to be reported in addition.  
 Note 3: For un-restricted bands, unwanted emissions shall be attenuated by at least 20 dB relative to the maximum measured in-band level.



<b>Polarization</b>	Horizontal	<b>Test Freq. (MHz)</b>	5745
<b>Test Configuration</b>	2		

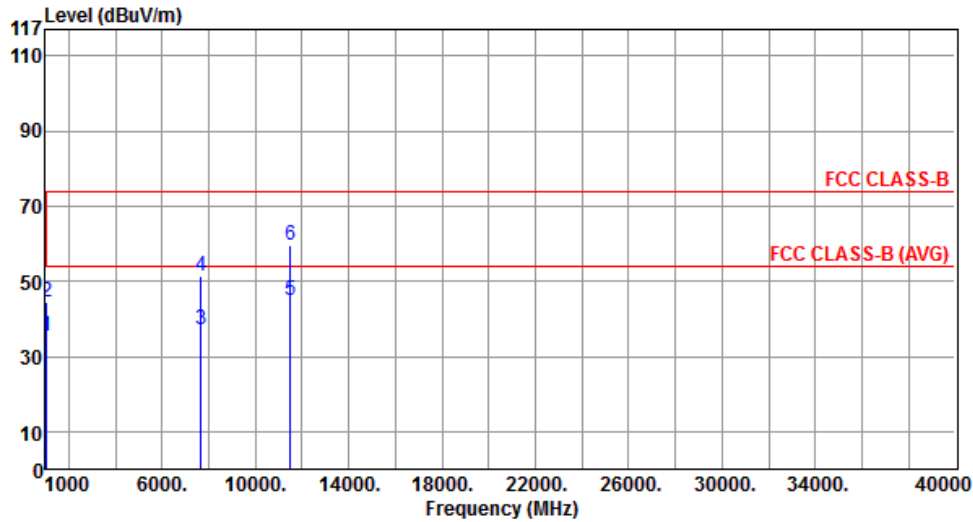

	Freq. MHz	Emission level dBuV/m	Limit dBuV/m	Margin dB	SA reading dBuV	Factor dB	Remark	ANT High cm	Turn Table deg
1	1050.00	35.30	54.00	-18.70	44.51	-9.21	Average	---	---
2	1050.00	44.47	74.00	-29.53	53.68	-9.21	Peak	---	---
3	7660.00	37.15	54.00	-16.85	27.52	9.63	Average	---	---
4	7660.00	51.26	74.00	-22.74	41.63	9.63	Peak	---	---
5	11490.00	45.07	54.00	-8.93	30.10	14.97	Average	---	---
6	11490.00	59.47	74.00	-14.53	44.50	14.97	Peak	---	---

Note 1: ">20dB" means spurious emission levels that exceed the level of 20 dB below the applicable limit.  
 Note 2: For restricted bands, the peak measurement is fully sufficient, as the max field strength as measured with the Peak-Detector meets the AV-Limit so that the AV level does not need to be reported in addition.  
 Note 3: For un-restricted bands, unwanted emissions shall be attenuated by at least 20 dB relative to the maximum measured in-band level.



<b>Polarization</b>	Vertical	<b>Test Freq. (MHz)</b>	5745
<b>Test Configuration</b>	2		

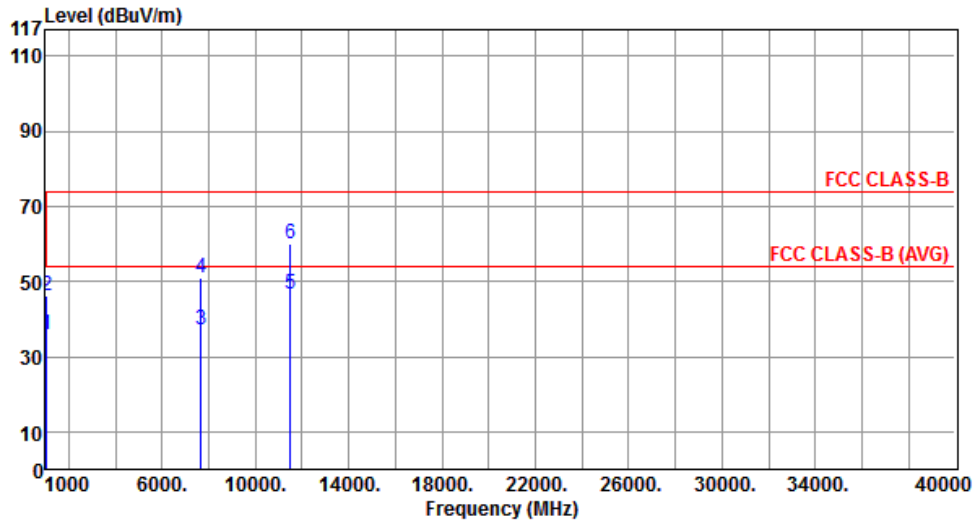

	Freq. MHz	Emission level dBuV/m	Limit dBuV/m	Margin dB	SA reading dBuV	Factor dB	Remark	ANT High cm	Turn Table deg
1	1050.00	35.95	54.00	-18.05	45.16	-9.21	Average	---	---
2	1050.00	46.08	74.00	-27.92	55.29	-9.21	Peak	---	---
3	7660.00	36.98	54.00	-17.02	27.35	9.63	Average	---	---
4	7660.00	51.11	74.00	-22.89	41.48	9.63	Peak	---	---
5	11490.00	46.81	54.00	-7.19	31.84	14.97	Average	---	---
6	11490.00	60.10	74.00	-13.90	45.13	14.97	Peak	---	---

Note 1: ">20dB" means spurious emission levels that exceed the level of 20 dB below the applicable limit.  
 Note 2: For restricted bands, the peak measurement is fully sufficient, as the max field strength as measured with the Peak-Detector meets the AV-Limit so that the AV level does not need to be reported in addition.  
 Note 3: For un-restricted bands, unwanted emissions shall be attenuated by at least 20 dB relative to the maximum measured in-band level.



<b>Polarization</b>	Horizontal	<b>Test Freq. (MHz)</b>	5785
<b>Test Configuration</b>	2		

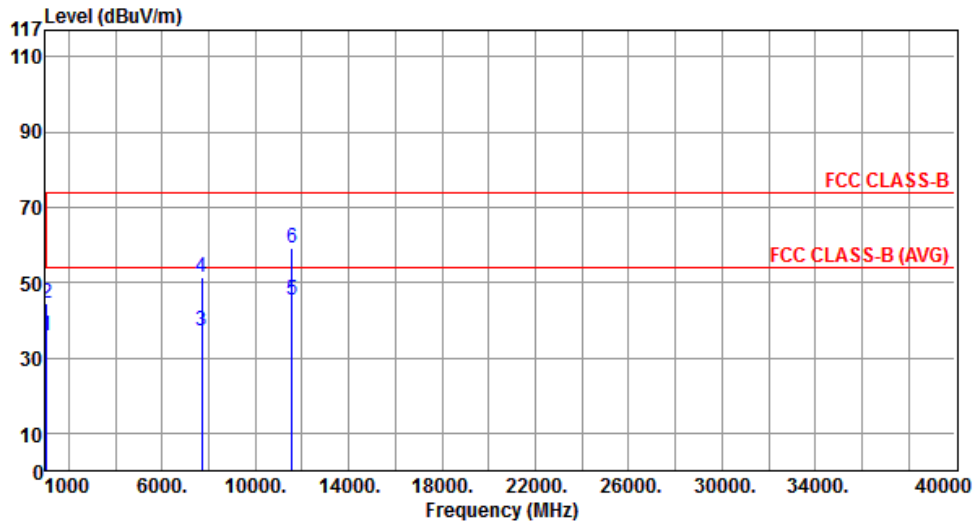

	Freq. MHz	Emission level dBuV/m	Limit dBuV/m	Margin dB	SA reading dBuV	Factor dB	Remark	ANT High cm	Turn Table deg
1	1050.00	35.75	54.00	-18.25	44.96	-9.21	Average	---	---
2	1050.00	44.63	74.00	-29.37	53.84	-9.21	Peak	---	---
3	7713.00	36.96	54.00	-17.04	27.29	9.67	Average	---	---
4	7713.00	51.20	74.00	-22.80	41.53	9.67	Peak	---	---
5	11570.00	45.44	54.00	-8.56	30.57	14.87	Average	---	---
6	11570.00	59.10	74.00	-14.90	44.23	14.87	Peak	---	---

Note 1: ">20dB" means spurious emission levels that exceed the level of 20 dB below the applicable limit.  
 Note 2: For restricted bands, the peak measurement is fully sufficient, as the max field strength as measured with the Peak-Detector meets the AV-Limit so that the AV level does not need to be reported in addition.  
 Note 3: For un-restricted bands, unwanted emissions shall be attenuated by at least 20 dB relative to the maximum measured in-band level.



<b>Polarization</b>	Vertical	<b>Test Freq. (MHz)</b>	5785
<b>Test Configuration</b>	2		

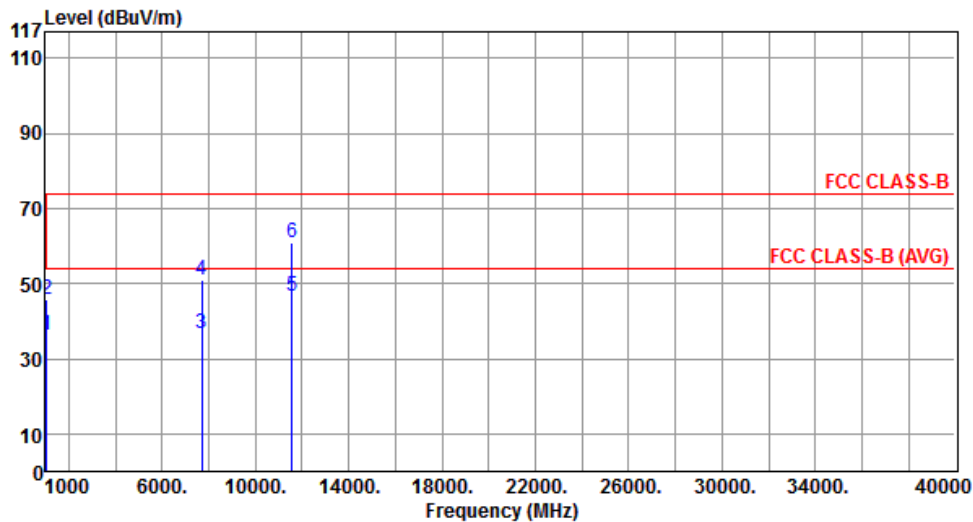

	Freq. MHz	Emission level dBuV/m	Limit dBuV/m	Margin dB	SA reading dBuV	Factor dB	Remark	ANT High cm	Turn Table deg
1	1050.00	36.06	54.00	-17.94	45.27	-9.21	Average	---	---
2	1050.00	45.95	74.00	-28.05	55.16	-9.21	Peak	---	---
3	7713.00	36.85	54.00	-17.15	27.18	9.67	Average	---	---
4	7713.00	51.15	74.00	-22.85	41.48	9.67	Peak	---	---
5	11570.00	46.67	54.00	-7.33	31.80	14.87	Average	---	---
6	11570.00	61.02	74.00	-12.98	46.15	14.87	Peak	---	---

Note 1: ">20dB" means spurious emission levels that exceed the level of 20 dB below the applicable limit.  
 Note 2: For restricted bands, the peak measurement is fully sufficient, as the max field strength as measured with the Peak-Detector meets the AV-Limit so that the AV level does not need to be reported in addition.  
 Note 3: For un-restricted bands, unwanted emissions shall be attenuated by at least 20 dB relative to the maximum measured in-band level.





<b>Polarization</b>	Horizontal	<b>Test Freq. (MHz)</b>	5825
<b>Test Configuration</b>	2		

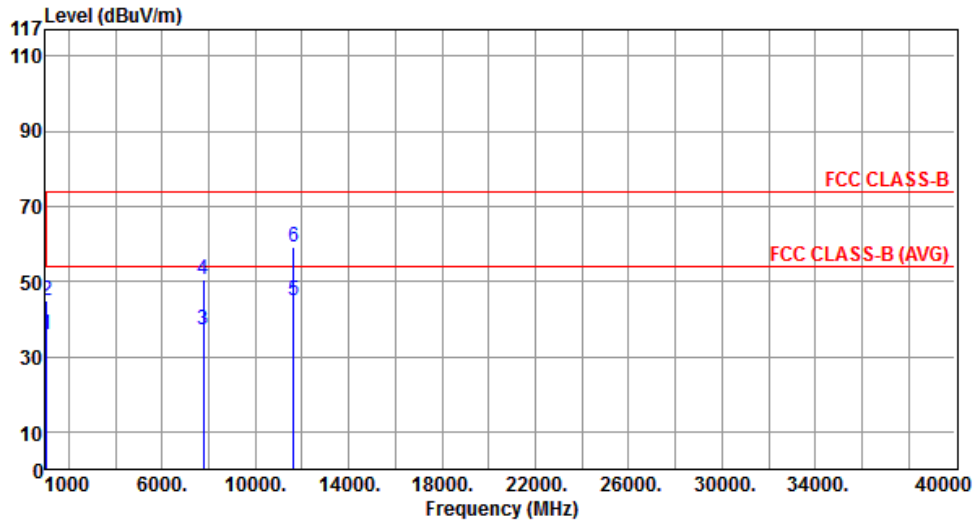

	Freq. MHz	Emission level dBuV/m	Limit dBuV/m	Margin dB	SA reading dBuV	Factor dB	Remark	ANT High cm	Turn Table deg
1	1050.00	35.71	54.00	-18.29	44.92	-9.21	Average	---	---
2	1050.00	45.06	74.00	-28.94	54.27	-9.21	Peak	---	---
3	7766.33	36.91	54.00	-17.09	27.20	9.71	Average	---	---
4	7766.33	50.66	74.00	-23.34	40.95	9.71	Peak	---	---
5	11650.00	44.90	54.00	-9.10	30.14	14.76	Average	---	---
6	11650.00	59.05	74.00	-14.95	44.29	14.76	Peak	---	---

Note 1: ">20dB" means spurious emission levels that exceed the level of 20 dB below the applicable limit.  
 Note 2: For restricted bands, the peak measurement is fully sufficient, as the max field strength as measured with the Peak-Detector meets the AV-Limit so that the AV level does not need to be reported in addition.  
 Note 3: For un-restricted bands, unwanted emissions shall be attenuated by at least 20 dB relative to the maximum measured in-band level.



<b>Polarization</b>	Vertical	<b>Test Freq. (MHz)</b>	5825
<b>Test Configuration</b>	2		

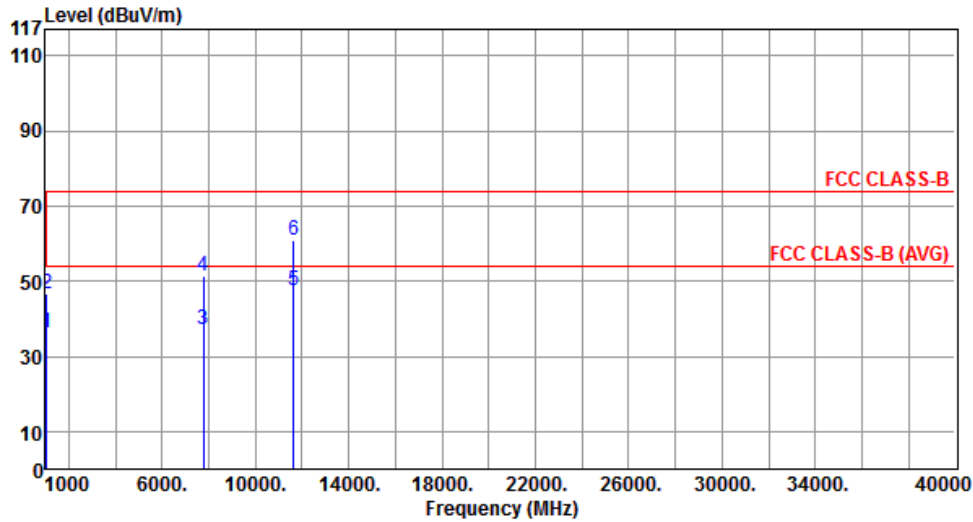

	Freq. MHz	Emission level dBuV/m	Limit dBuV/m	Margin dB	SA reading dBuV	Factor dB	Remark	ANT High cm	Turn Table deg
1	1050.00	36.13	54.00	-17.87	45.34	-9.21	Average	---	---
2	1050.00	46.59	74.00	-27.41	55.80	-9.21	Peak	---	---
3	7766.33	37.29	54.00	-16.71	27.58	9.71	Average	---	---
4	7766.33	51.58	74.00	-22.42	41.87	9.71	Peak	---	---
5	11650.00	47.33	54.00	-6.67	32.57	14.76	Average	---	---
6	11650.00	60.90	74.00	-13.10	46.14	14.76	Peak	---	---

Note 1: ">20dB" means spurious emission levels that exceed the level of 20 dB below the applicable limit.  
 Note 2: For restricted bands, the peak measurement is fully sufficient, as the max field strength as measured with the Peak-Detector meets the AV-Limit so that the AV level does not need to be reported in addition.  
 Note 3: For un-restricted bands, unwanted emissions shall be attenuated by at least 20 dB relative to the maximum measured in-band level.



<b>Polarization</b>	Horizontal	<b>Test Freq. (MHz)</b>	5745
<b>Test Configuration</b>	3		

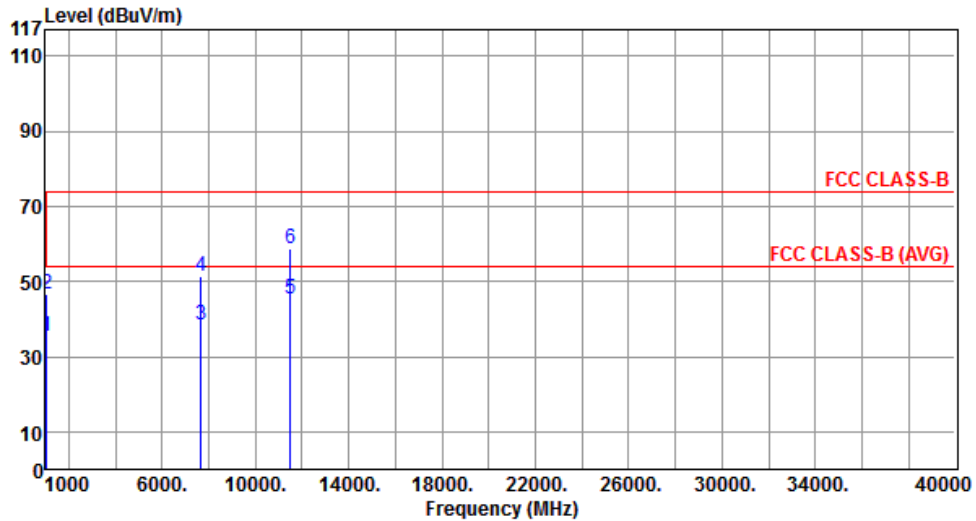

	Freq. MHz	Emission level dBuV/m	Limit dBuV/m	Margin dB	SA reading dBuV	Factor dB	Remark	ANT High cm	Turn Table deg
1	1050.00	35.58	54.00	-18.42	44.79	-9.21	Average	---	---
2	1050.00	46.47	74.00	-27.53	55.68	-9.21	Peak	---	---
3	7660.00	38.22	54.00	-15.78	28.59	9.63	Average	---	---
4	7660.00	51.55	74.00	-22.45	41.92	9.63	Peak	---	---
5	11490.00	45.31	54.00	-8.69	30.34	14.97	Average	---	---
6	11490.00	58.63	74.00	-15.37	43.66	14.97	Peak	---	---

Note 1: ">20dB" means spurious emission levels that exceed the level of 20 dB below the applicable limit.  
 Note 2: For restricted bands, the peak measurement is fully sufficient, as the max field strength as measured with the Peak-Detector meets the AV-Limit so that the AV level does not need to be reported in addition.  
 Note 3: For un-restricted bands, unwanted emissions shall be attenuated by at least 20 dB relative to the maximum measured in-band level.



<b>Polarization</b>	Vertical	<b>Test Freq. (MHz)</b>	5745
<b>Test Configuration</b>	3		

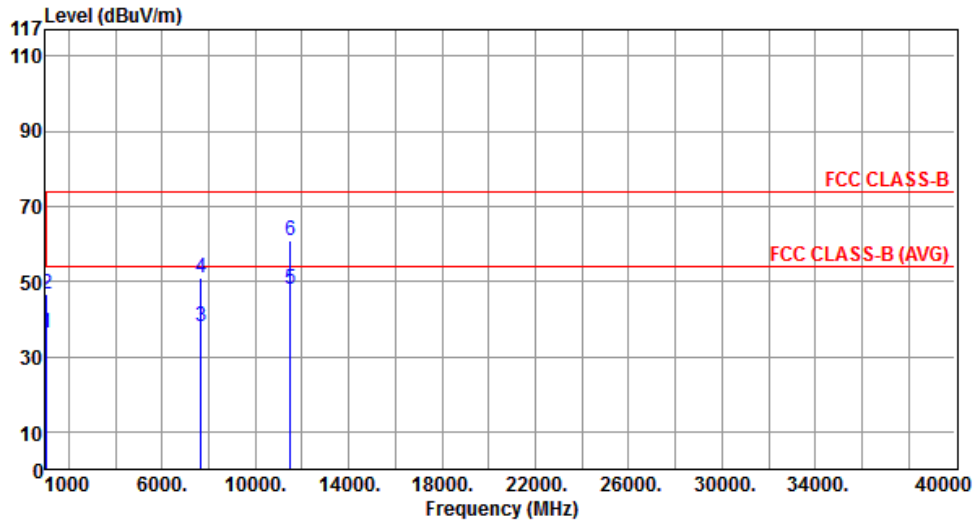

	Freq. MHz	Emission level dBuV/m	Limit dBuV/m	Margin dB	SA reading dBuV	Factor dB	Remark	ANT High cm	Turn Table deg
1	1050.00	36.15	54.00	-17.85	45.36	-9.21	Average	---	---
2	1050.00	46.71	74.00	-27.29	55.92	-9.21	Peak	---	---
3	7660.00	38.04	54.00	-15.96	28.41	9.63	Average	---	---
4	7660.00	50.92	74.00	-23.08	41.29	9.63	Peak	---	---
5	11490.00	47.81	54.00	-6.19	32.84	14.97	Average	---	---
6	11490.00	61.09	74.00	-12.91	46.12	14.97	Peak	---	---

Note 1: ">20dB" means spurious emission levels that exceed the level of 20 dB below the applicable limit.  
 Note 2: For restricted bands, the peak measurement is fully sufficient, as the max field strength as measured with the Peak-Detector meets the AV-Limit so that the AV level does not need to be reported in addition.  
 Note 3: For un-restricted bands, unwanted emissions shall be attenuated by at least 20 dB relative to the maximum measured in-band level.



<b>Polarization</b>	Horizontal	<b>Test Freq. (MHz)</b>	5785
<b>Test Configuration</b>	3		

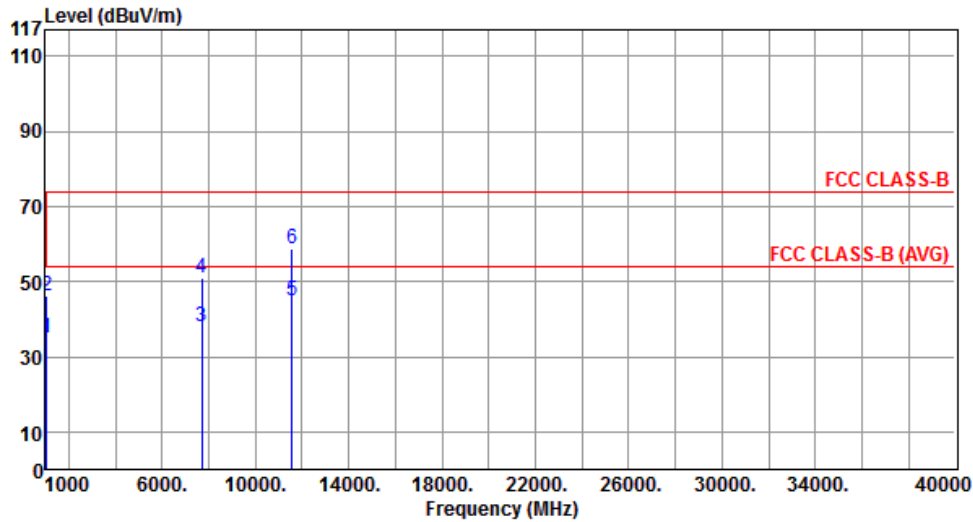

	Freq. MHz	Emission level dBuV/m	Limit dBuV/m	Margin dB	SA reading dBuV	Factor dB	Remark	ANT High cm	Turn Table deg
1	1050.00	35.15	54.00	-18.85	44.36	-9.21	Average	---	---
2	1050.00	46.04	74.00	-27.96	55.25	-9.21	Peak	---	---
3	7713.00	38.01	54.00	-15.99	28.34	9.67	Average	---	---
4	7713.00	50.96	74.00	-23.04	41.29	9.67	Peak	---	---
5	11570.00	44.90	54.00	-9.10	30.03	14.87	Average	---	---
6	11570.00	58.64	74.00	-15.36	43.77	14.87	Peak	---	---

Note 1: ">20dB" means spurious emission levels that exceed the level of 20 dB below the applicable limit.  
 Note 2: For restricted bands, the peak measurement is fully sufficient, as the max field strength as measured with the Peak-Detector meets the AV-Limit so that the AV level does not need to be reported in addition.  
 Note 3: For un-restricted bands, unwanted emissions shall be attenuated by at least 20 dB relative to the maximum measured in-band level.



<b>Polarization</b>	Vertical	<b>Test Freq. (MHz)</b>	5785
<b>Test Configuration</b>	3		

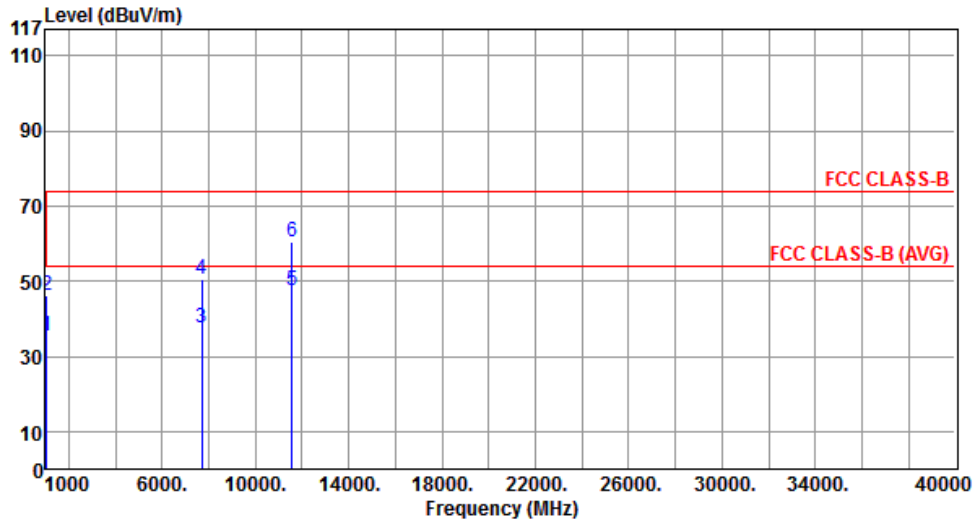

	Freq. MHz	Emission level dBuV/m	Limit dBuV/m	Margin dB	SA reading dBuV	Factor dB	Remark	ANT High cm	Turn Table deg
1	1050.00	35.35	54.00	-18.65	44.56	-9.21	Average	---	---
2	1050.00	46.13	74.00	-27.87	55.34	-9.21	Peak	---	---
3	7713.00	37.74	54.00	-16.26	28.07	9.67	Average	---	---
4	7713.00	50.35	74.00	-23.65	40.68	9.67	Peak	---	---
5	11570.00	47.50	54.00	-6.50	32.63	14.87	Average	---	---
6	11570.00	60.33	74.00	-13.67	45.46	14.87	Peak	---	---

Note 1: ">20dB" means spurious emission levels that exceed the level of 20 dB below the applicable limit.  
 Note 2: For restricted bands, the peak measurement is fully sufficient, as the max field strength as measured with the Peak-Detector meets the AV-Limit so that the AV level does not need to be reported in addition.  
 Note 3: For un-restricted bands, unwanted emissions shall be attenuated by at least 20 dB relative to the maximum measured in-band level.



<b>Polarization</b>	Horizontal	<b>Test Freq. (MHz)</b>	5825
<b>Test Configuration</b>	3		

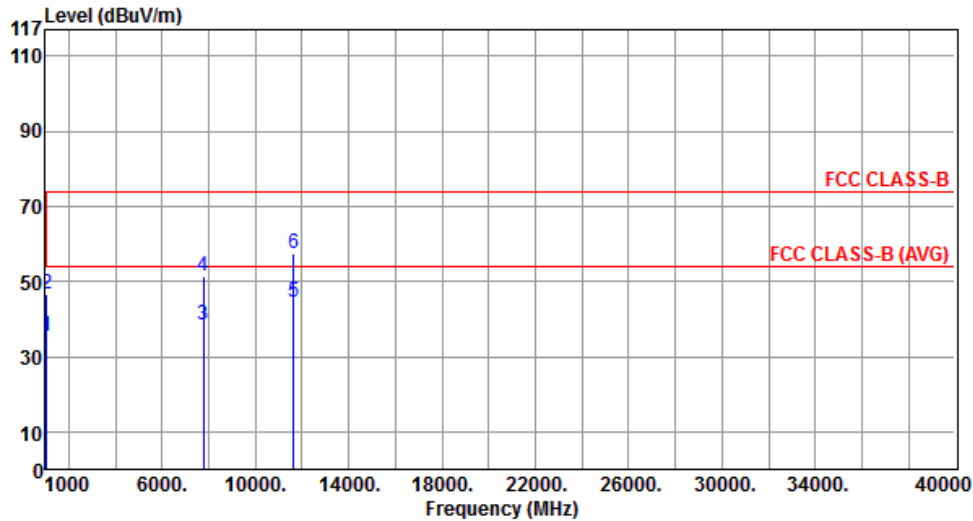

	Freq. MHz	Emission level dBuV/m	Limit dBuV/m	Margin dB	SA reading dBuV	Factor dB	Remark	ANT High cm	Turn Table deg
1	1050.00	35.49	54.00	-18.51	44.70	-9.21	Average	---	---
2	1050.00	46.42	74.00	-27.58	55.63	-9.21	Peak	---	---
3	7766.33	38.22	54.00	-15.78	28.51	9.71	Average	---	---
4	7766.33	51.38	74.00	-22.62	41.67	9.71	Peak	---	---
5	11650.00	44.44	54.00	-9.56	29.68	14.76	Average	---	---
6	11650.00	57.55	74.00	-16.45	42.79	14.76	Peak	---	---

Note 1: ">20dB" means spurious emission levels that exceed the level of 20 dB below the applicable limit.  
 Note 2: For restricted bands, the peak measurement is fully sufficient, as the max field strength as measured with the Peak-Detector meets the AV-Limit so that the AV level does not need to be reported in addition.  
 Note 3: For un-restricted bands, unwanted emissions shall be attenuated by at least 20 dB relative to the maximum measured in-band level.



<b>Polarization</b>	Vertical	<b>Test Freq. (MHz)</b>	5825
<b>Test Configuration</b>	3		

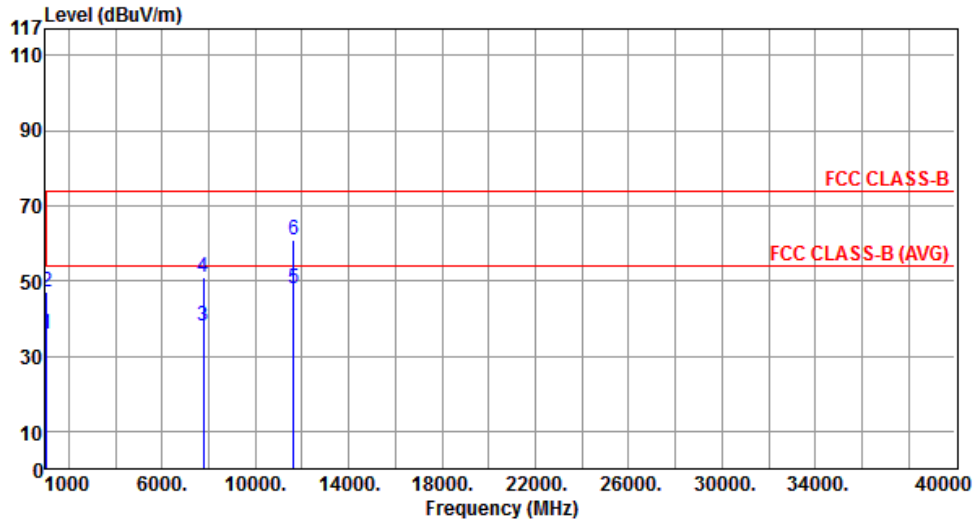

	Freq. MHz	Emission level dBuV/m	Limit dBuV/m	Margin dB	SA reading dBuV	Factor dB	Remark	ANT High cm	Turn Table deg
1	1050.00	35.70	54.00	-18.30	44.91	-9.21	Average	---	---
2	1050.00	47.03	74.00	-26.97	56.24	-9.21	Peak	---	---
3	7766.33	37.97	54.00	-16.03	28.26	9.71	Average	---	---
4	7766.33	51.06	74.00	-22.94	41.35	9.71	Peak	---	---
5	11650.00	47.86	54.00	-6.14	33.10	14.76	Average	---	---
6	11650.00	60.96	74.00	-13.04	46.20	14.76	Peak	---	---

Note 1: ">20dB" means spurious emission levels that exceed the level of 20 dB below the applicable limit.  
 Note 2: For restricted bands, the peak measurement is fully sufficient, as the max field strength as measured with the Peak-Detector meets the AV-Limit so that the AV level does not need to be reported in addition.  
 Note 3: For un-restricted bands, unwanted emissions shall be attenuated by at least 20 dB relative to the maximum measured in-band level.





### 3.5.6 Transmitter Radiated Unwanted Emissions (Above 1GHz) for HT20

Polarization	Horizontal	Test Freq. (MHz)	5745						
Test Configuration	1								
	Freq. MHz	Emission level dBuV/m	Limit dBuV/m	Margin dB	SA reading dBuV	Factor dB	Remark	ANT High cm	Turn Table deg
1	1050.00	35.44	54.00	-18.56	44.65	-9.21	Average	---	---
2	1050.00	46.52	74.00	-27.48	55.73	-9.21	Peak	---	---
3	7660.00	36.43	54.00	-17.57	26.80	9.63	Average	---	---
4	7660.00	49.62	74.00	-24.38	39.99	9.63	Peak	---	---
5	11490.00	44.55	54.00	-9.45	29.58	14.97	Average	---	---
6	11490.00	57.68	74.00	-16.32	42.71	14.97	Peak	---	---
<p>Note 1: "&gt;20dB" means spurious emission levels that exceed the level of 20 dB below the applicable limit.</p> <p>Note 2: For restricted bands, the peak measurement is fully sufficient, as the max field strength as measured with the Peak-Detector meets the AV-Limit so that the AV level does not need to be reported in addition.</p> <p>Note 3: For un-restricted bands, unwanted emissions shall be attenuated by at least 20 dB relative to the maximum measured in-band level.</p>									



<b>Polarization</b>	Vertical	<b>Test Freq. (MHz)</b>	5745
<b>Test Configuration</b>	1		

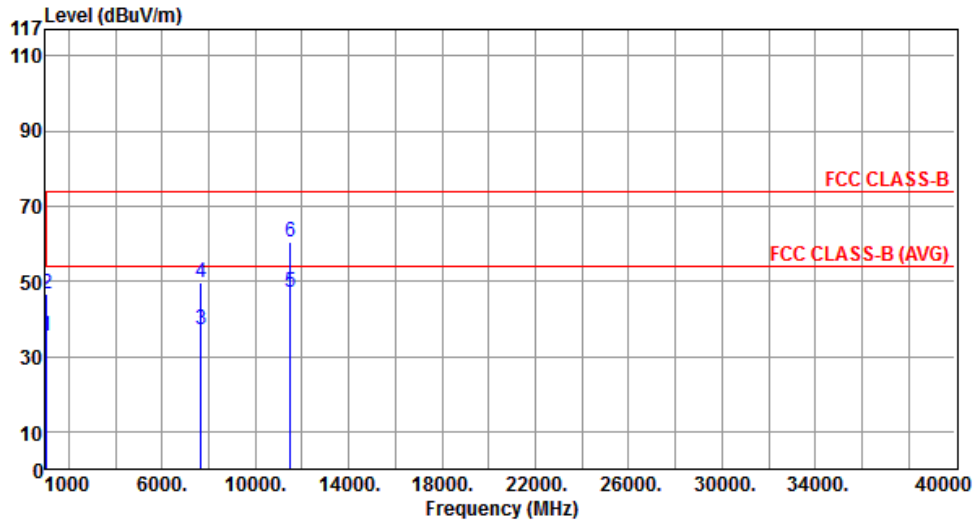

	Freq. MHz	Emission level dBuV/m	Limit dBuV/m	Margin dB	SA reading dBuV	Factor dB	Remark	ANT High cm	Turn Table deg
1	1050.00	35.26	54.00	-18.74	44.47	-9.21	Average	---	---
2	1050.00	46.43	74.00	-27.57	55.64	-9.21	Peak	---	---
3	7660.00	37.26	54.00	-16.74	27.63	9.63	Average	---	---
4	7660.00	49.56	74.00	-24.44	39.93	9.63	Peak	---	---
5	11490.00	47.16	54.00	-6.84	32.19	14.97	Average	---	---
6	11490.00	60.35	74.00	-13.65	45.38	14.97	Peak	---	---

Note 1: ">20dB" means spurious emission levels that exceed the level of 20 dB below the applicable limit.  
 Note 2: For restricted bands, the peak measurement is fully sufficient, as the max field strength as measured with the Peak-Detector meets the AV-Limit so that the AV level does not need to be reported in addition.  
 Note 3: For un-restricted bands, unwanted emissions shall be attenuated by at least 20 dB relative to the maximum measured in-band level.



<b>Polarization</b>	Horizontal	<b>Test Freq. (MHz)</b>	5785
<b>Test Configuration</b>	1		

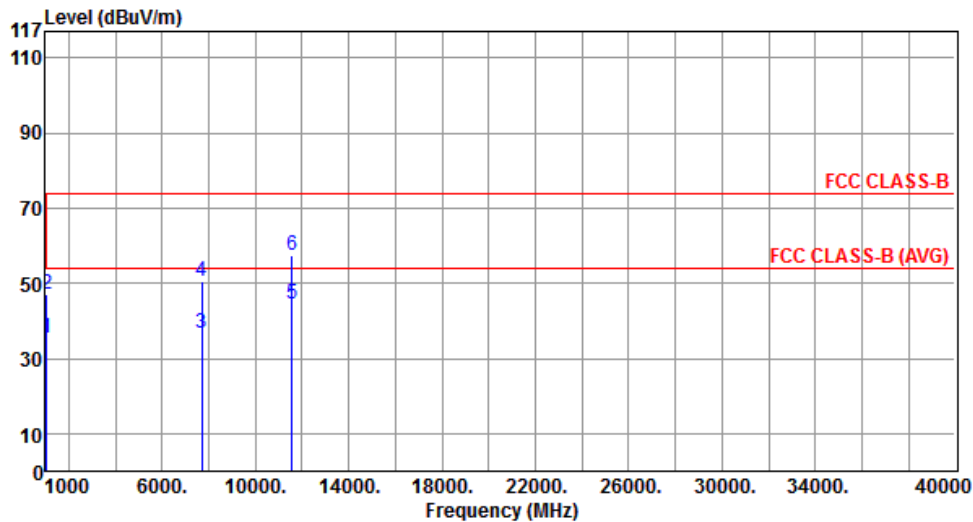

	Freq. MHz	Emission level dBuV/m	Limit dBuV/m	Margin dB	SA reading dBuV	Factor dB	Remark	ANT High cm	Turn Table deg
1	1050.00	35.46	54.00	-18.54	44.67	-9.21	Average	---	---
2	1050.00	46.92	74.00	-27.08	56.13	-9.21	Peak	---	---
3	7713.00	36.76	54.00	-17.24	27.09	9.67	Average	---	---
4	7713.00	50.46	74.00	-23.54	40.79	9.67	Peak	---	---
5	11570.00	44.26	54.00	-9.74	29.39	14.87	Average	---	---
6	11570.00	57.26	74.00	-16.74	42.39	14.87	Peak	---	---

Note 1: ">20dB" means spurious emission levels that exceed the level of 20 dB below the applicable limit.  
 Note 2: For restricted bands, the peak measurement is fully sufficient, as the max field strength as measured with the Peak-Detector meets the AV-Limit so that the AV level does not need to be reported in addition.  
 Note 3: For un-restricted bands, unwanted emissions shall be attenuated by at least 20 dB relative to the maximum measured in-band level.



<b>Polarization</b>	Vertical	<b>Test Freq. (MHz)</b>	5785
<b>Test Configuration</b>	1		

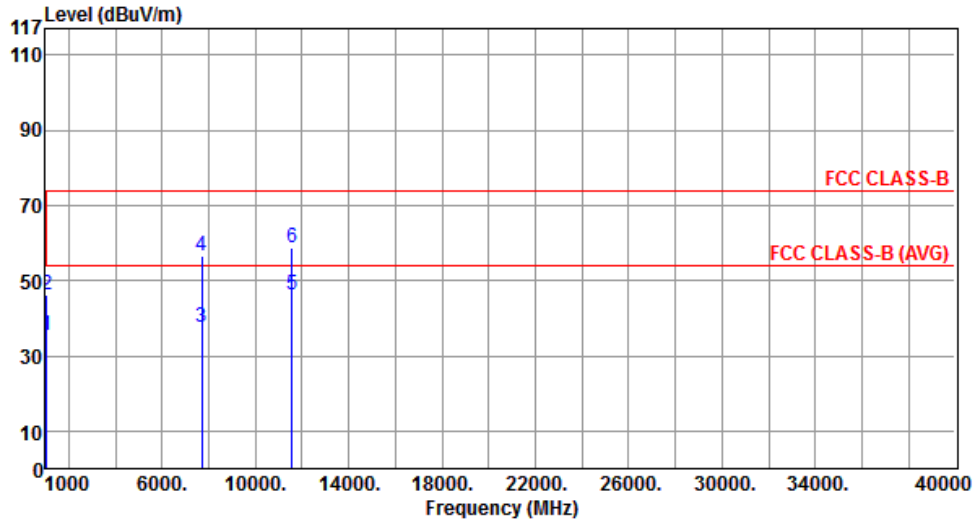

	Freq. MHz	Emission level dBuV/m	Limit dBuV/m	Margin dB	SA reading dBuV	Factor dB	Remark	ANT High cm	Turn Table deg
1	1050.00	35.38	54.00	-18.62	44.59	-9.21	Average	---	---
2	1050.00	46.41	74.00	-27.59	55.62	-9.21	Peak	---	---
3	7713.00	37.35	54.00	-16.65	27.68	9.67	Average	---	---
4	7713.00	56.42	74.00	-17.58	46.75	9.67	Peak	---	---
5	11570.00	46.26	54.00	-7.74	31.39	14.87	Average	---	---
6	11570.00	58.63	74.00	-15.37	43.76	14.87	Peak	---	---

Note 1: ">20dB" means spurious emission levels that exceed the level of 20 dB below the applicable limit.  
 Note 2: For restricted bands, the peak measurement is fully sufficient, as the max field strength as measured with the Peak-Detector meets the AV-Limit so that the AV level does not need to be reported in addition.  
 Note 3: For un-restricted bands, unwanted emissions shall be attenuated by at least 20 dB relative to the maximum measured in-band level.



<b>Polarization</b>	Horizontal	<b>Test Freq. (MHz)</b>	5825
<b>Test Configuration</b>	1		

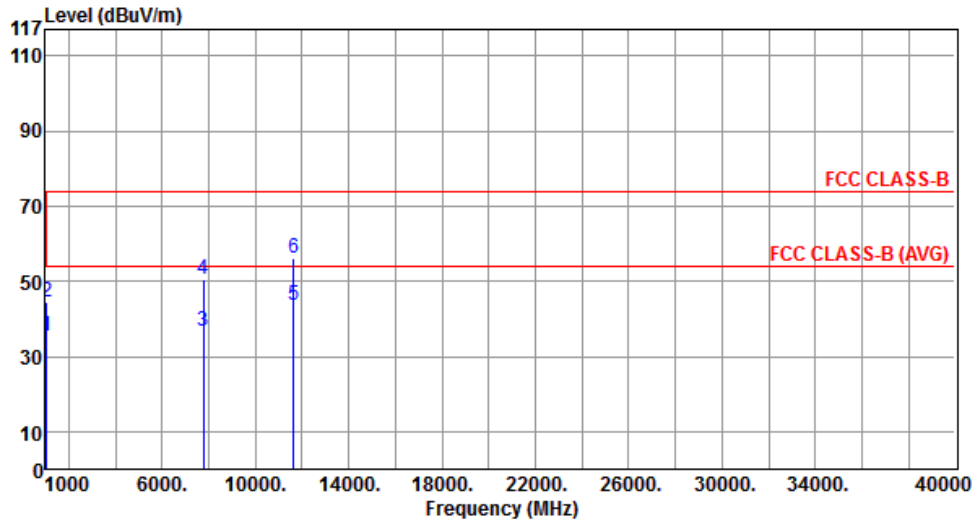

	Freq. MHz	Emission level dBuV/m	Limit dBuV/m	Margin dB	SA reading dBuV	Factor dB	Remark	ANT High cm	Turn Table deg
1	1050.00	35.35	54.00	-18.65	44.56	-9.21	Average	---	---
2	1050.00	44.42	74.00	-29.58	53.63	-9.21	Peak	---	---
3	7766.33	36.68	54.00	-17.32	26.97	9.71	Average	---	---
4	7766.33	50.49	74.00	-23.51	40.78	9.71	Peak	---	---
5	11650.00	43.52	54.00	-10.48	28.76	14.76	Average	---	---
6	11650.00	55.91	74.00	-18.09	41.15	14.76	Peak	---	---

Note 1: ">20dB" means spurious emission levels that exceed the level of 20 dB below the applicable limit.  
 Note 2: For restricted bands, the peak measurement is fully sufficient, as the max field strength as measured with the Peak-Detector meets the AV-Limit so that the AV level does not need to be reported in addition.  
 Note 3: For un-restricted bands, unwanted emissions shall be attenuated by at least 20 dB relative to the maximum measured in-band level.



<b>Polarization</b>	Vertical	<b>Test Freq. (MHz)</b>	5825
<b>Test Configuration</b>	1		

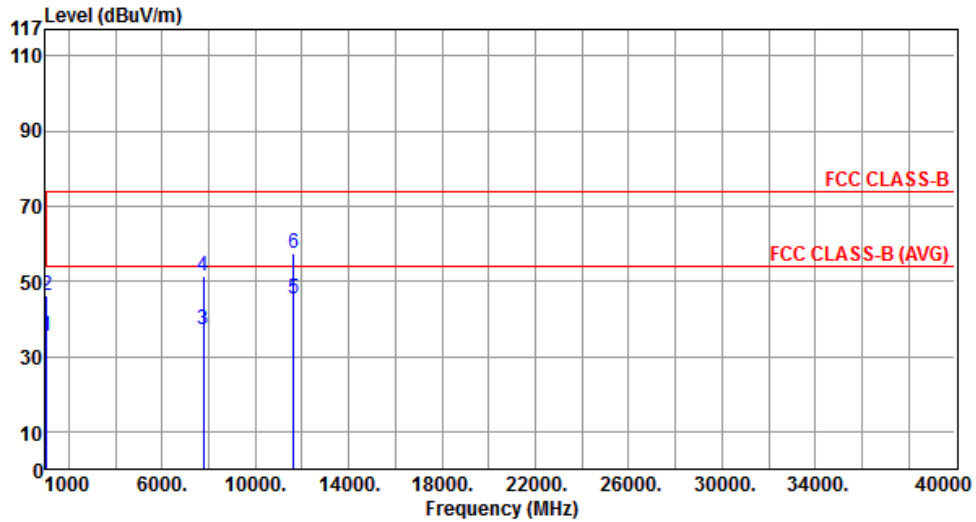

	Freq. MHz	Emission level dBuV/m	Limit dBuV/m	Margin dB	SA reading dBuV	Factor dB	Remark	ANT High cm	Turn Table deg
1	1050.00	35.43	54.00	-18.57	44.64	-9.21	Average	---	---
2	1050.00	46.26	74.00	-27.74	55.47	-9.21	Peak	---	---
3	7766.00	37.32	54.00	-16.68	27.61	9.71	Average	---	---
4	7766.00	51.21	74.00	-22.79	41.50	9.71	Peak	---	---
5	11650.00	45.26	54.00	-8.74	30.50	14.76	Average	---	---
6	11650.00	57.35	74.00	-16.65	42.59	14.76	Peak	---	---

Note 1: ">20dB" means spurious emission levels that exceed the level of 20 dB below the applicable limit.  
 Note 2: For restricted bands, the peak measurement is fully sufficient, as the max field strength as measured with the Peak-Detector meets the AV-Limit so that the AV level does not need to be reported in addition.  
 Note 3: For un-restricted bands, unwanted emissions shall be attenuated by at least 20 dB relative to the maximum measured in-band level.



<b>Polarization</b>	Horizontal	<b>Test Freq. (MHz)</b>	5745
<b>Test Configuration</b>	2		

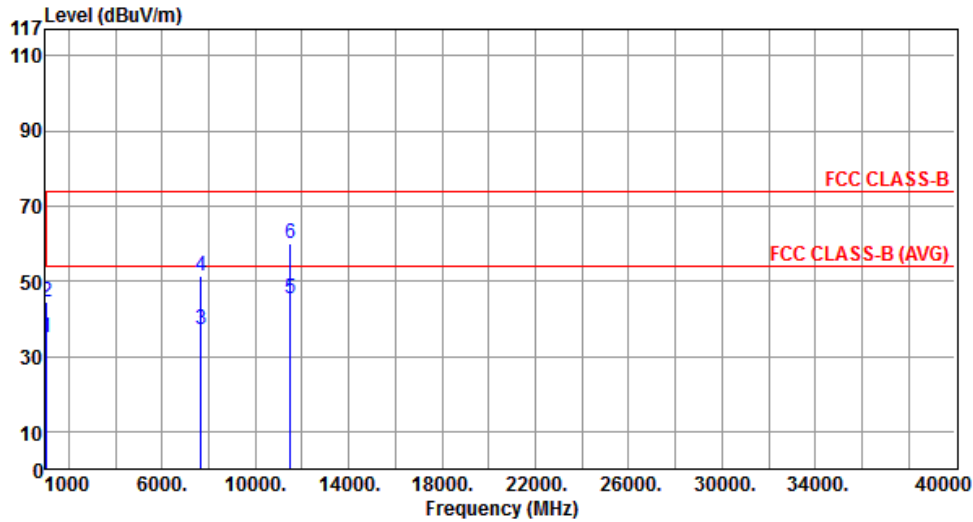

	Freq. MHz	Emission level dBuV/m	Limit dBuV/m	Margin dB	SA reading dBuV	Factor dB	Remark	ANT High cm	Turn Table deg
1	1050.00	35.16	54.00	-18.84	44.37	-9.21	Average	---	---
2	1050.00	44.31	74.00	-29.69	53.52	-9.21	Peak	---	---
3	7660.00	37.31	54.00	-16.69	27.68	9.63	Average	---	---
4	7660.00	51.58	74.00	-22.42	41.95	9.63	Peak	---	---
5	11490.00	45.22	54.00	-8.78	30.25	14.97	Average	---	---
6	11490.00	59.81	74.00	-14.19	44.84	14.97	Peak	---	---

Note 1: ">20dB" means spurious emission levels that exceed the level of 20 dB below the applicable limit.  
 Note 2: For restricted bands, the peak measurement is fully sufficient, as the max field strength as measured with the Peak-Detector meets the AV-Limit so that the AV level does not need to be reported in addition.  
 Note 3: For un-restricted bands, unwanted emissions shall be attenuated by at least 20 dB relative to the maximum measured in-band level.



<b>Polarization</b>	Vertical	<b>Test Freq. (MHz)</b>	5745
<b>Test Configuration</b>	2		

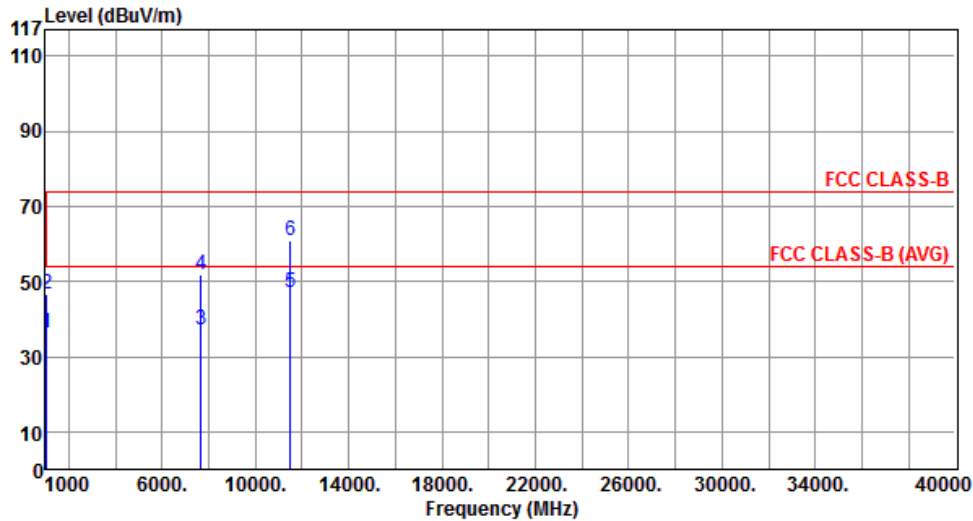

	Freq. MHz	Emission level dBuV/m	Limit dBuV/m	Margin dB	SA reading dBuV	Factor dB	Remark	ANT High cm	Turn Table deg
1	1050.00	36.12	54.00	-17.88	45.33	-9.21	Average	---	---
2	1050.00	46.43	74.00	-27.57	55.64	-9.21	Peak	---	---
3	7660.00	37.31	54.00	-16.69	27.68	9.63	Average	---	---
4	7660.00	51.60	74.00	-22.40	41.97	9.63	Peak	---	---
5	11490.00	46.99	54.00	-7.01	32.02	14.97	Average	---	---
6	11490.00	60.88	74.00	-13.12	45.91	14.97	Peak	---	---

Note 1: ">20dB" means spurious emission levels that exceed the level of 20 dB below the applicable limit.  
 Note 2: For restricted bands, the peak measurement is fully sufficient, as the max field strength as measured with the Peak-Detector meets the AV-Limit so that the AV level does not need to be reported in addition.  
 Note 3: For un-restricted bands, unwanted emissions shall be attenuated by at least 20 dB relative to the maximum measured in-band level.





<b>Polarization</b>	Horizontal	<b>Test Freq. (MHz)</b>	5785
<b>Test Configuration</b>	2		

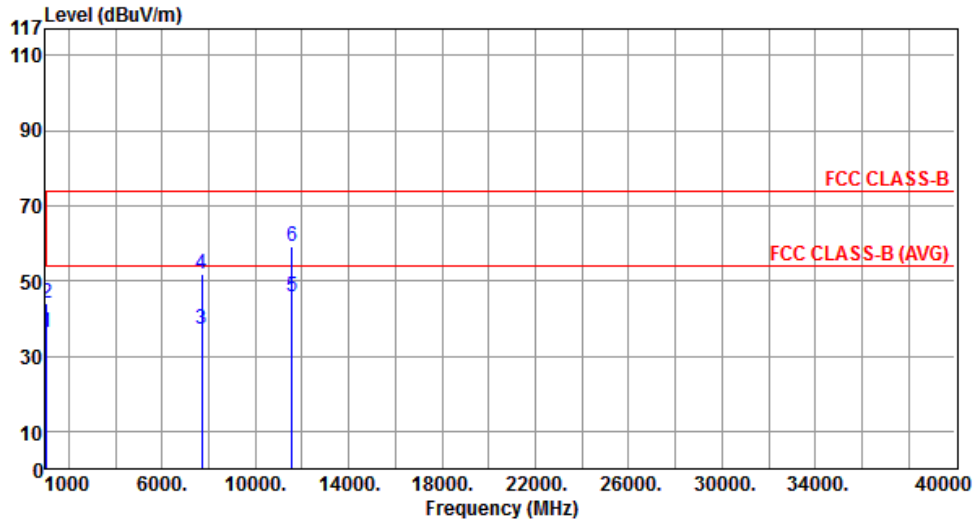

	Freq. MHz	Emission level dBuV/m	Limit dBuV/m	Margin dB	SA reading dBuV	Factor dB	Remark	ANT High cm	Turn Table deg
1	1050.00	36.16	54.00	-17.84	45.37	-9.21	Average	---	---
2	1050.00	44.21	74.00	-29.79	53.42	-9.21	Peak	---	---
3	7713.00	37.22	54.00	-16.78	27.55	9.67	Average	---	---
4	7713.00	51.64	74.00	-22.36	41.97	9.67	Peak	---	---
5	11570.00	45.71	54.00	-8.29	30.84	14.87	Average	---	---
6	11570.00	59.26	74.00	-14.74	44.39	14.87	Peak	---	---

Note 1: ">20dB" means spurious emission levels that exceed the level of 20 dB below the applicable limit.

Note 2: For restricted bands, the peak measurement is fully sufficient, as the max field strength as measured with the Peak-Detector meets the AV-Limit so that the AV level does not need to be reported in addition.

Note 3: For un-restricted bands, unwanted emissions shall be attenuated by at least 20 dB relative to the maximum measured in-band level.



<b>Polarization</b>	Vertical	<b>Test Freq. (MHz)</b>	5785
<b>Test Configuration</b>	2		

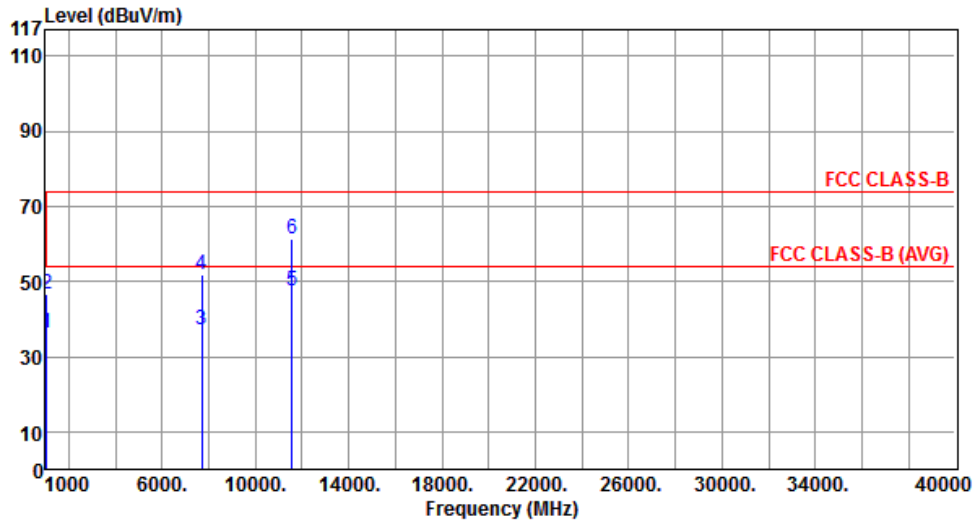

	Freq. MHz	Emission level dBuV/m	Limit dBuV/m	Margin dB	SA reading dBuV	Factor dB	Remark	ANT High cm	Turn Table deg
1	1050.00	36.17	54.00	-17.83	45.38	-9.21	Average	---	---
2	1050.00	46.63	74.00	-27.37	55.84	-9.21	Peak	---	---
3	7713.00	37.23	54.00	-16.77	27.56	9.67	Average	---	---
4	7713.00	51.63	74.00	-22.37	41.96	9.67	Peak	---	---
5	11570.00	47.39	54.00	-6.61	32.52	14.87	Average	---	---
6	11570.00	61.45	74.00	-12.55	46.58	14.87	Peak	---	---

Note 1: ">20dB" means spurious emission levels that exceed the level of 20 dB below the applicable limit.  
 Note 2: For restricted bands, the peak measurement is fully sufficient, as the max field strength as measured with the Peak-Detector meets the AV-Limit so that the AV level does not need to be reported in addition.  
 Note 3: For un-restricted bands, unwanted emissions shall be attenuated by at least 20 dB relative to the maximum measured in-band level.



<b>Polarization</b>	Horizontal	<b>Test Freq. (MHz)</b>	5825
<b>Test Configuration</b>	2		

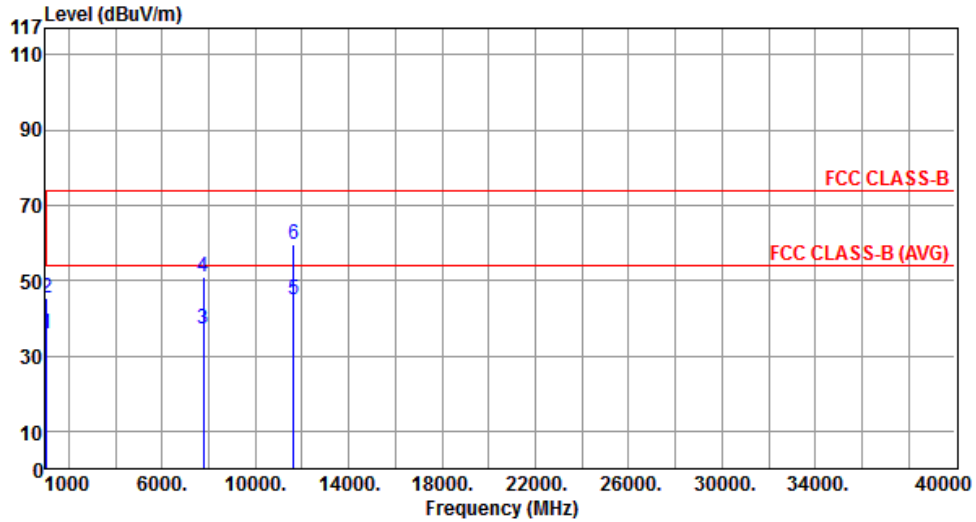

	Freq. MHz	Emission level dBuV/m	Limit dBuV/m	Margin dB	SA reading dBuV	Factor dB	Remark	ANT High cm	Turn Table deg
1	1050.00	36.03	54.00	-17.97	45.24	-9.21	Average	---	---
2	1050.00	45.37	74.00	-28.63	54.58	-9.21	Peak	---	---
3	7766.33	37.31	54.00	-16.69	27.60	9.71	Average	---	---
4	7766.33	50.98	74.00	-23.02	41.27	9.71	Peak	---	---
5	11650.00	45.11	54.00	-8.89	30.35	14.76	Average	---	---
6	11650.00	59.40	74.00	-14.60	44.64	14.76	Peak	---	---

Note 1: ">20dB" means spurious emission levels that exceed the level of 20 dB below the applicable limit.  
 Note 2: For restricted bands, the peak measurement is fully sufficient, as the max field strength as measured with the Peak-Detector meets the AV-Limit so that the AV level does not need to be reported in addition.  
 Note 3: For un-restricted bands, unwanted emissions shall be attenuated by at least 20 dB relative to the maximum measured in-band level.



<b>Polarization</b>	Vertical	<b>Test Freq. (MHz)</b>	5825
<b>Test Configuration</b>	2		

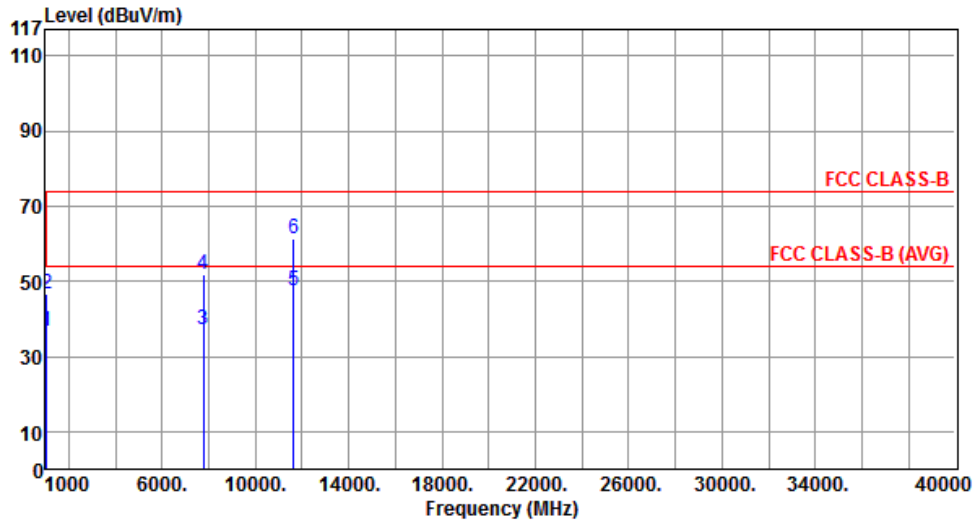

	Freq. MHz	Emission level dBuV/m	Limit dBuV/m	Margin dB	SA reading dBuV	Factor dB	Remark	ANT High cm	Turn Table deg
1	1050.00	36.63	54.00	-17.37	45.84	-9.21	Average	---	---
2	1050.00	46.51	74.00	-27.49	55.72	-9.21	Peak	---	---
3	7766.33	37.17	54.00	-16.83	27.46	9.71	Average	---	---
4	7766.33	51.62	74.00	-22.38	41.91	9.71	Peak	---	---
5	11650.00	47.62	54.00	-6.38	32.86	14.76	Average	---	---
6	11650.00	61.30	74.00	-12.70	46.54	14.76	Peak	---	---

Note 1: ">20dB" means spurious emission levels that exceed the level of 20 dB below the applicable limit.

Note 2: For restricted bands, the peak measurement is fully sufficient, as the max field strength as measured with the Peak-Detector meets the AV-Limit so that the AV level does not need to be reported in addition.

Note 3: For un-restricted bands, unwanted emissions shall be attenuated by at least 20 dB relative to the maximum measured in-band level.



<b>Polarization</b>	Horizontal	<b>Test Freq. (MHz)</b>	5745
<b>Test Configuration</b>	3		

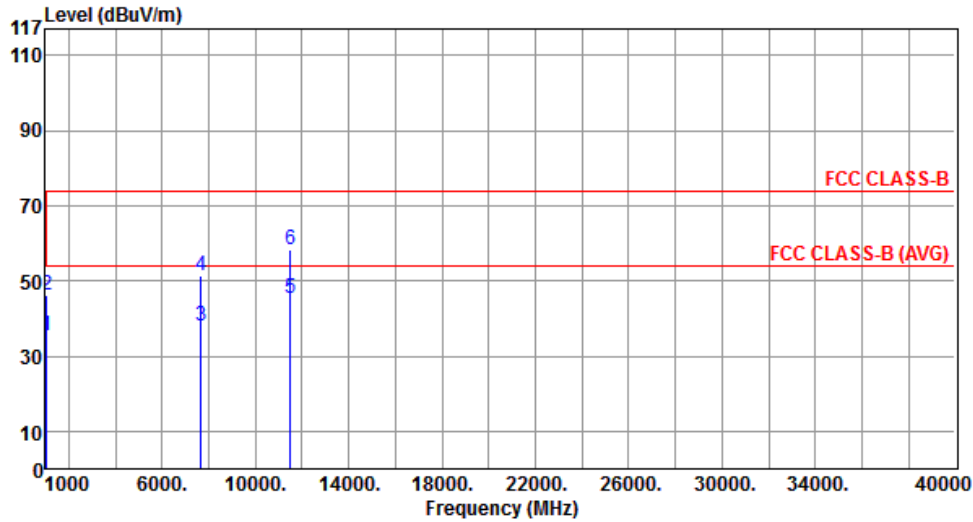

	Freq. MHz	Emission level dBuV/m	Limit dBuV/m	Margin dB	SA reading dBuV	Factor dB	Remark	ANT High cm	Turn Table deg
1	1050.00	35.35	54.00	-18.65	44.56	-9.21	Average	---	---
2	1050.00	46.26	74.00	-27.74	55.47	-9.21	Peak	---	---
3	7660.00	38.05	54.00	-15.95	28.42	9.63	Average	---	---
4	7660.00	51.46	74.00	-22.54	41.83	9.63	Peak	---	---
5	11490.00	45.25	54.00	-8.75	30.28	14.97	Average	---	---
6	11490.00	58.27	74.00	-15.73	43.30	14.97	Peak	---	---

Note 1: ">20dB" means spurious emission levels that exceed the level of 20 dB below the applicable limit.  
 Note 2: For restricted bands, the peak measurement is fully sufficient, as the max field strength as measured with the Peak-Detector meets the AV-Limit so that the AV level does not need to be reported in addition.  
 Note 3: For un-restricted bands, unwanted emissions shall be attenuated by at least 20 dB relative to the maximum measured in-band level.



<b>Polarization</b>	Vertical	<b>Test Freq. (MHz)</b>	5745
<b>Test Configuration</b>	3		

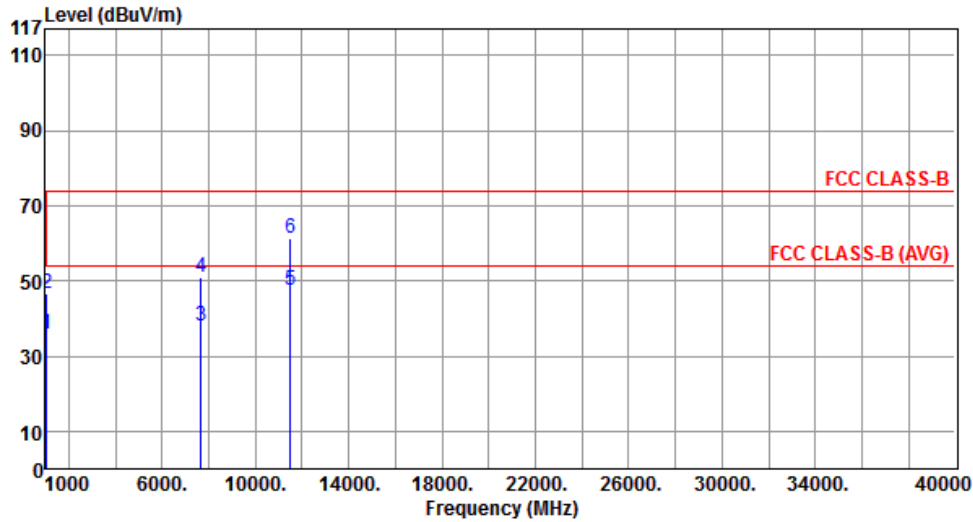

	Freq. MHz	Emission level dBuV/m	Limit dBuV/m	Margin dB	SA reading dBuV	Factor dB	Remark	ANT High cm	Turn Table deg
1	1050.00	35.96	54.00	-18.04	45.17	-9.21	Average	---	---
2	1050.00	46.47	74.00	-27.53	55.68	-9.21	Peak	---	---
3	7660.00	37.96	54.00	-16.04	28.33	9.63	Average	---	---
4	7660.00	51.08	74.00	-22.92	41.45	9.63	Peak	---	---
5	11490.00	47.60	54.00	-6.40	32.63	14.97	Average	---	---
6	11490.00	61.49	74.00	-12.51	46.52	14.97	Peak	---	---

Note 1: ">20dB" means spurious emission levels that exceed the level of 20 dB below the applicable limit.  
 Note 2: For restricted bands, the peak measurement is fully sufficient, as the max field strength as measured with the Peak-Detector meets the AV-Limit so that the AV level does not need to be reported in addition.  
 Note 3: For un-restricted bands, unwanted emissions shall be attenuated by at least 20 dB relative to the maximum measured in-band level.



<b>Polarization</b>	Horizontal	<b>Test Freq. (MHz)</b>	5785
<b>Test Configuration</b>	3		

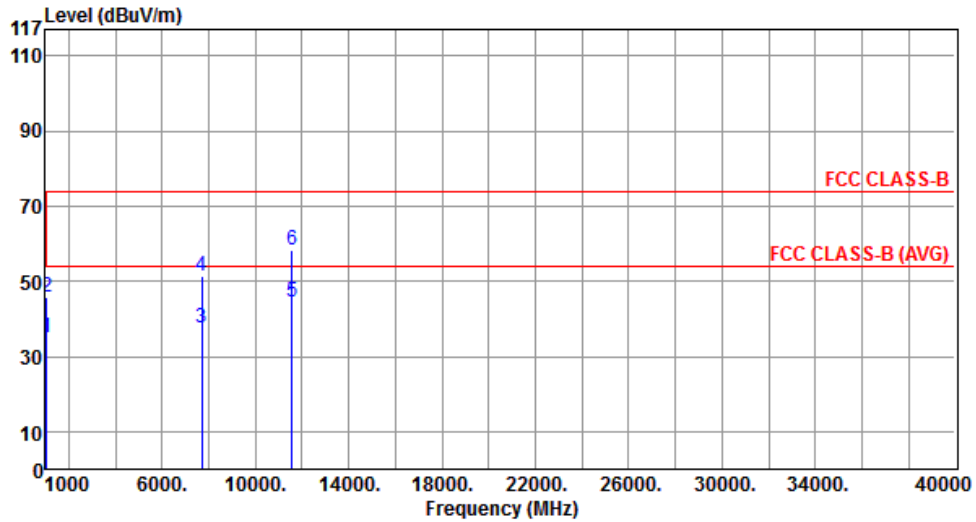

	Freq. MHz	Emission level dBuV/m	Limit dBuV/m	Margin dB	SA reading dBuV	Factor dB	Remark	ANT High cm	Turn Table deg
1	1050.00	34.98	54.00	-19.02	44.19	-9.21	Average	---	---
2	1050.00	45.92	74.00	-28.08	55.13	-9.21	Peak	---	---
3	7713.00	37.75	54.00	-16.25	28.08	9.67	Average	---	---
4	7713.00	51.32	74.00	-22.68	41.65	9.67	Peak	---	---
5	11570.00	44.61	54.00	-9.39	29.74	14.87	Average	---	---
6	11570.00	58.39	74.00	-15.61	43.52	14.87	Peak	---	---

Note 1: ">20dB" means spurious emission levels that exceed the level of 20 dB below the applicable limit.  
 Note 2: For restricted bands, the peak measurement is fully sufficient, as the max field strength as measured with the Peak-Detector meets the AV-Limit so that the AV level does not need to be reported in addition.  
 Note 3: For un-restricted bands, unwanted emissions shall be attenuated by at least 20 dB relative to the maximum measured in-band level.



<b>Polarization</b>	Vertical	<b>Test Freq. (MHz)</b>	5785
<b>Test Configuration</b>	3		

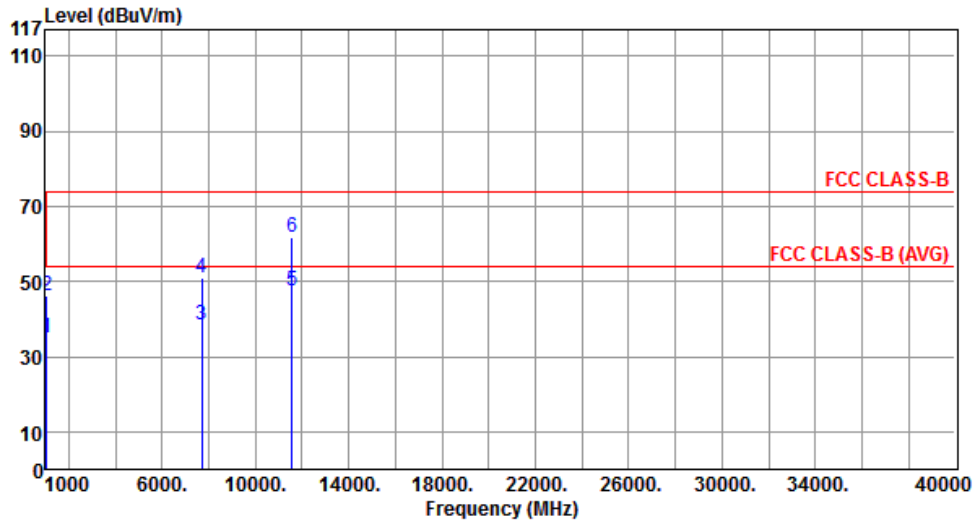

	Freq. MHz	Emission level dBuV/m	Limit dBuV/m	Margin dB	SA reading dBuV	Factor dB	Remark	ANT High cm	Turn Table deg
1	1050.00	35.17	54.00	-18.83	44.38	-9.21	Average	---	---
2	1050.00	46.41	74.00	-27.59	55.62	-9.21	Peak	---	---
3	7713.00	38.26	54.00	-15.74	28.59	9.67	Average	---	---
4	7713.00	51.00	74.00	-23.00	41.33	9.67	Peak	---	---
5	11570.00	47.70	54.00	-6.30	32.83	14.87	Average	---	---
6	11570.00	61.65	74.00	-12.35	46.78	14.87	Peak	---	---

Note 1: ">20dB" means spurious emission levels that exceed the level of 20 dB below the applicable limit.  
 Note 2: For restricted bands, the peak measurement is fully sufficient, as the max field strength as measured with the Peak-Detector meets the AV-Limit so that the AV level does not need to be reported in addition.  
 Note 3: For un-restricted bands, unwanted emissions shall be attenuated by at least 20 dB relative to the maximum measured in-band level.





<b>Polarization</b>	Horizontal	<b>Test Freq. (MHz)</b>	5825
<b>Test Configuration</b>	3		

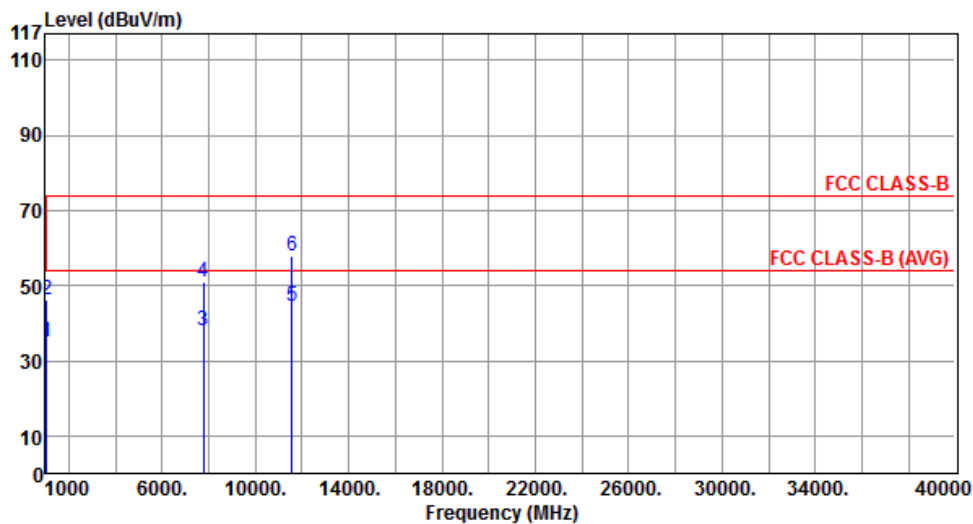

	Freq. MHz	Emission level dBuV/m	Limit dBuV/m	Margin dB	SA reading dBuV	Factor dB	Remark	ANT High cm	Turn Table deg
1	1050.00	35.17	54.00	-18.83	44.38	-9.21	Average	---	---
2	1050.00	46.06	74.00	-27.94	55.27	-9.21	Peak	---	---
3	7766.33	37.86	54.00	-16.14	28.15	9.71	Average	---	---
4	7766.33	51.08	74.00	-22.92	41.37	9.71	Peak	---	---
5	11570.00	44.39	54.00	-9.61	29.52	14.87	Average	---	---
6	11570.00	57.81	74.00	-16.19	42.94	14.87	Peak	---	---

Note 1: ">20dB" means spurious emission levels that exceed the level of 20 dB below the applicable limit.  
 Note 2: For restricted bands, the peak measurement is fully sufficient, as the max field strength as measured with the Peak-Detector meets the AV-Limit so that the AV level does not need to be reported in addition.  
 Note 3: For un-restricted bands, unwanted emissions shall be attenuated by at least 20 dB relative to the maximum measured in-band level.



<b>Polarization</b>	Vertical	<b>Test Freq. (MHz)</b>	5825
<b>Test Configuration</b>	3		

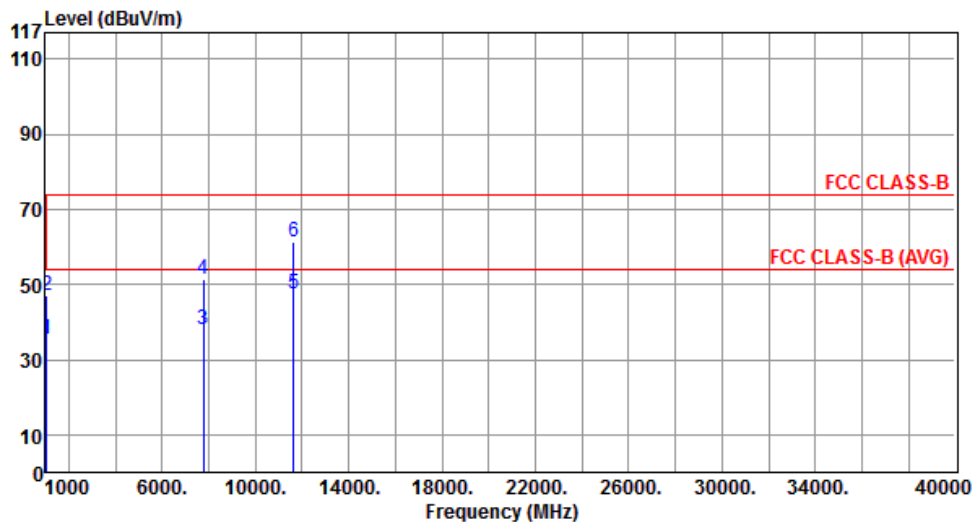

	Freq. MHz	Emission level dBuV/m	Limit dBuV/m	Margin dB	SA reading dBuV	Factor dB	Remark	ANT High cm	Turn Table deg
1	1050.00	35.43	54.00	-18.57	44.64	-9.21	Average	---	---
2	1050.00	46.96	74.00	-27.04	56.17	-9.21	Peak	---	---
3	7766.33	38.09	54.00	-15.91	28.38	9.71	Average	---	---
4	7766.33	51.52	74.00	-22.48	41.81	9.71	Peak	---	---
5	11650.00	47.42	54.00	-6.58	32.66	14.76	Average	---	---
6	11650.00	61.30	74.00	-12.70	46.54	14.76	Peak	---	---

Note 1: ">20dB" means spurious emission levels that exceed the level of 20 dB below the applicable limit.  
 Note 2: For restricted bands, the peak measurement is fully sufficient, as the max field strength as measured with the Peak-Detector meets the AV-Limit so that the AV level does not need to be reported in addition.  
 Note 3: For un-restricted bands, unwanted emissions shall be attenuated by at least 20 dB relative to the maximum measured in-band level.



## 3.6 Unwanted Emissions into Non-Restricted Frequency Bands

### 3.6.1 Limit of Unwanted Emissions into Non-Restricted Frequency Bands

- The peak output power measured in any 100 kHz bandwidth outside of the authorized frequency band shall be attenuated by at least 20 dB relative to the maximum in-band peak PSD level in 100 kHz.
- The peak power in any 100 kHz bandwidth outside of the authorized frequency band shall be attenuated by at least 30 dB relative to the maximum in-band peak PSD level in 100 kHz.

### 3.6.2 Test Procedures

#### Reference Level Measurement

1. Set the RBW = 100 kHz, VBW = 300 kHz, Detector = peak.
2. Set Sweep time = auto couple, Trace mode = max hold.
3. Allow trace to fully stabilize.
4. Use the peak marker function to determine the maximum amplitude level.

#### Unwanted Emissions Level Measurement

1. Set RBW = 100 kHz, VBW = 300 kHz, Detector = peak.
2. Trace Mode = max hold, Sweep = auto couple.
3. Allow the trace to stabilize.
4. Use peak marker function to determine maximum amplitude of all unwanted emissions within any 100 kHz bandwidth.

### 3.6.3 Test Setup

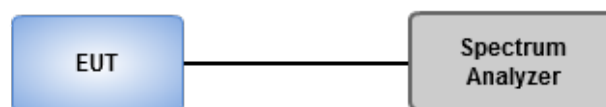



### 3.6.4 Unwanted Emissions into Non-Restricted Frequency Bands for 11a

Transmitter Radiated Bandedge Emissions Result								
Test Configuration		1						
Modulation	11a			N <sub>TX</sub>	1			
Non-restricted Band (MHz)	Test Ch. Freq. (MHz)	In-band PSD [i] (dBuV/100kHz)	NBE Freq. (MHz)	Out-band PSD [o] (dBuV/100kHz)	[i] – [o] (dB)	Limit (dB)	Level Type	Pol. note 1
5460-5725	5745	100.87	5724.97	65.63	35.24	20	PK	H
5460-5725	5745	106.21	5724.97	70.19	36.02	20	PK	V
5850-7250	5825	101.32	5850.25	57.42	43.9	20	PK	H
5850-7250	5825	106.12	5853.17	63.09	43.03	20	PK	V
Low Bandedge - H				Up Bandedge - H				
Low Bandedge - V				Up Bandedge - V				
Note 1: Measurement worst emissions of receive antenna polarization: H (Horizontal) or V (Vertical)								



**Transmitter Radiated Bandedge Emissions Result**

Test Configuration		2						
Modulation	11a			N <sub>TX</sub>	1			
Non-restricted Band (MHz)	Test Ch. Freq. (MHz)	In-band PSD [i] (dBuV/100kHz)	NBE Freq. (MHz)	Out-band PSD [o] (dBuV/100kHz)	[i] – [o] (dB)	Limit (dB)	Level Type	Pol. note 1
5460-5725	5745	95.97	5724.97	59.83	36.14	20	PK	H
5460-5725	5745	108.29	5724.97	71.35	36.94	20	PK	V
5850-7250	5825	96.92	5851.57	53.24	43.68	20	PK	H
5850-7250	5825	108.83	5850.25	62.57	46.26	20	PK	V
Low Bandedge - H				Up Bandedge - H				
Low Bandedge - V				Up Bandedge - V				
<p>Note 1: Measurement worst emissions of receive antenna polarization: H (Horizontal) or V (Vertical)</p>								



**Transmitter Radiated Bandedge Emissions Result**

Test Configuration		3						
Modulation	11a			N <sub>TX</sub>	1			
Non-restricted Band (MHz)	Test Ch. Freq. (MHz)	In-band PSD [i] (dBuV/100kHz)	NBE Freq. (MHz)	Out-band PSD [o] (dBuV/100kHz)	[i] – [o] (dB)	Limit (dB)	Level Type	Pol. note 1
5460-5725	5745	103.51	5724.97	64.69	38.82	20	PK	H
5460-5725	5745	100.82	5724.97	62.7	38.12	20	PK	V
5850-7250	5825	103.23	5850.64	58.3	44.93	20	PK	H
5850-7250	5825	101.37	5850.64	55.79	45.58	20	PK	V
<b>Low Bandedge - H</b>				<b>Up Bandedge - H</b>				
<b>Low Bandedge - V</b>				<b>Up Bandedge - V</b>				
<p>Note 1: Measurement worst emissions of receive antenna polarization: H (Horizontal) or V (Vertical)</p>								



### 3.6.5 Unwanted Emissions into Non-Restricted Frequency Bands for HT20

Transmitter Radiated Bandedge Emissions Result								
Test Configuration		1						
Modulation	HT20			N <sub>TX</sub>	1			
Non-restricted Band (MHz)	Test Ch. Freq. (MHz)	In-band PSD [i] (dBuV/100kHz)	NBE Freq. (MHz)	Out-band PSD [o] (dBuV/100kHz)	[i] – [o] (dB)	Limit (dB)	Level Type	Pol. note 1
5460-5725	5745	101.05	5724.97	66.5	34.55	20	PK	H
5460-5725	5745	106.64	5724.97	71.92	34.72	20	PK	V
5850-7250	5825	101.32	5850.69	58.16	43.16	20	PK	H
5850-7250	5825	106.25	5850	62.31	43.94	20	PK	V
Low Bandedge - H				Up Bandedge - H				
Low Bandedge - V				Up Bandedge - V				
Note 1: Measurement worst emissions of receive antenna polarization: H (Horizontal) or V (Vertical)								



**Transmitter Radiated Bandedge Emissions Result**

Test Configuration		2						
Modulation	HT20			N <sub>TX</sub>	1			
Non-restricted Band (MHz)	Test Ch. Freq. (MHz)	In-band PSD [i] (dBuV/100kHz)	NBE Freq. (MHz)	Out-band PSD [o] (dBuV/100kHz)	[i] – [o] (dB)	Limit (dB)	Level Type	Pol. note 1
5460-5725	5745	95.44	5724.97	59.89	35.55	20	PK	H
5460-5725	5745	108.49	5724.97	72.49	36	20	PK	V
5850-7250	5825	96.29	5850	55.17	41.12	20	PK	H
5850-7250	5825	108.76	5850.09	65.25	43.51	20	PK	V
<b>Low Bandedge - H</b>				<b>Up Bandedge - H</b>				
<b>Low Bandedge - V</b>				<b>Up Bandedge - V</b>				
<p>Note 1: Measurement worst emissions of receive antenna polarization: H (Horizontal) or V (Vertical)</p>								





**Transmitter Radiated Bandedge Emissions Result**

Test Configuration		3						
Modulation	HT20			N <sub>TX</sub>	1			
Non-restricted Band (MHz)	Test Ch. Freq. (MHz)	In-band PSD [i] (dBuV/100kHz)	NBE Freq. (MHz)	Out-band PSD [o] (dBuV/100kHz)	[i] - [o] (dB)	Limit (dB)	Level Type	Pol. note 1
5460-5725	5745	103.96	5724.97	66.71	37.25	20	PK	H
5460-5725	5745	100.7	5724.97	62.86	37.84	20	PK	V
5850-7250	5825	103.47	5850.09	59.83	43.64	20	PK	H
5850-7250	5825	101.44	5850.695	57.48	43.96	20	PK	V
Low Bandedge - H				Up Bandedge - H				
Low Bandedge - V				Up Bandedge - V				
<p>Note 1: Measurement worst emissions of receive antenna polarization: H (Horizontal) or V (Vertical)</p>								

==END==